



پورتال تخصصی
مواد مهندسی
و فرایندهای
ساخت و تولید

www.asremavad.com

@asremavad

VISIT US ON:     



Welding of Pipelines and Related Facilities

API STANDARD 1104
TWENTY-FIRST EDITION, SEPTEMBER 2013

ERRATA 1, APRIL 2014
ERRATA 2, JUNE 2014
ERRATA 3, JULY 2014
ERRATA 4, NOVEMBER 2015
ADDENDUM 1, JULY 2014
ADDENDUM 2, MAY 2016



AMERICAN PETROLEUM INSTITUTE

Special Notes

API publications necessarily address problems of a general nature. With respect to particular circumstances, local, state, and federal laws and regulations should be reviewed.

Neither API nor any of API's employees, subcontractors, consultants, committees, or other assignees make any warranty or representation, either express or implied, with respect to the accuracy, completeness, or usefulness of the information contained herein, or assume any liability or responsibility for any use, or the results of such use, of any information or process disclosed in this publication. Neither API nor any of API's employees, subcontractors, consultants, or other assignees represent that use of this publication would not infringe upon privately owned rights.

API publications may be used by anyone desiring to do so. Every effort has been made by the Institute to assure the accuracy and reliability of the data contained in them; however, the Institute makes no representation, warranty, or guarantee in connection with this publication and hereby expressly disclaims any liability or responsibility for loss or damage resulting from its use or for the violation of any authorities having jurisdiction with which this publication may conflict.

API publications are published to facilitate the broad availability of proven, sound engineering and operating practices. These publications are not intended to obviate the need for applying sound engineering judgment regarding when and where these publications should be utilized. The formulation and publication of API publications is not intended in any way to inhibit anyone from using any other practices.

Any manufacturer marking equipment or materials in conformance with the marking requirements of an API standard is solely responsible for complying with all the applicable requirements of that standard. API does not represent, warrant, or guarantee that such products do in fact conform to the applicable API standard.

Classified areas may vary depending on the location, conditions, equipment, and substances involved in any given situation. Users of this Standard should consult with the appropriate authorities having jurisdiction.

Users of this Standard should not rely exclusively on the information contained in this document. Sound business, scientific, engineering, and safety judgment should be used in employing the information contained herein.

All rights reserved. No part of this work may be reproduced, translated, stored in a retrieval system, or transmitted by any means, electronic, mechanical, photocopying, recording, or otherwise, without prior written permission from the publisher. Contact the Publisher, API Publishing Services, 1220 L Street, NW, Washington, DC 20005.

Copyright © 2013 American Petroleum Institute

Foreword

This standard was prepared by a formulating committee that included representatives of the API, the American Gas Association (AGA), the Pipe Line Contractors Association (PLCA), the American Welding Society (AWS), and the American Society for Nondestructive Testing (ASNT), as well as representatives of pipe manufacturers and individuals associated with related industries.

The purpose of this standard is to present methods for the production of high quality welds through the use of qualified welders using approved welding procedures, materials, and equipment. Its purpose is also to present inspection methods to ensure the proper analysis of welding quality through the use of qualified technicians and approved methods and equipment. It applies to both new construction and in-service welding.

The use of this standard is entirely voluntary and is intended to apply to welding of piping used in the compression, pumping, and transmission of crude petroleum, petroleum products, fuel gases, carbon dioxide, and nitrogen and, where applicable, to distribution systems.

This standard represents the combined efforts of many engineers who are responsible for the design, construction, and operation of oil and gas pipelines, and the committee appreciatively acknowledges their wholehearted and valuable assistance.

Nothing contained in any API publication is to be construed as granting any right, by implication or otherwise, for the manufacture, sale, or use of any method, apparatus, or product covered by letters patent. Neither should anything contained in the publication be construed as insuring anyone against liability for infringement of letters patent.

Shall: As used in a standard, "shall" denotes a minimum requirement in order to conform to the specification.

Should: As used in a standard, "should" denotes a recommendation or that which is advised but not required in order to conform to the specification.

This document was produced under API standardization procedures that ensure appropriate notification and participation in the developmental process and is designated as an API standard. Questions concerning the interpretation of the content of this publication or comments and questions concerning the procedures under which this publication was developed should be directed in writing to the Director of Standards, American Petroleum Institute, 1220 L Street, NW, Washington, DC 20005. Requests for permission to reproduce or translate all or any part of the material published herein should also be addressed to the director.

Generally, API standards are reviewed and revised, reaffirmed, or withdrawn at least every five years. A one-time extension of up to two years may be added to this review cycle. Status of the publication can be ascertained from the API Standards Department, telephone (202) 682-8000. A catalog of API publications and materials is published annually by API, 1220 L Street, NW, Washington, DC 20005.

Suggested revisions are invited and should be submitted to the Standards Department, API, 1220 L Street, NW, Washington, DC 20005, standards@api.org.

Contents

Page

1	Scope	1
2	Normative References	1
3	Terms, Definitions, Acronyms, and Abbreviations	2
3.1	Terms and Definitions	2
3.2	Acronyms and Abbreviations	5
4	Specifications	8
4.1	Equipment	8
4.2	Materials	8
5	Qualification of Welding Procedures with Filler Metal Additions	9
5.1	Procedure Qualification	9
5.2	Record	9
5.3	Welding Procedure Specification	9
5.4	Essential Variables	13
5.5	Welding of Test Joints—Butt Welds	16
5.6	Testing of Welded Joints—Butt Welds	16
5.7	Welding of Test Joints—Fillet Welds	23
5.8	Testing of Welded Joints—Fillet Welds	23
6	Qualification of Welders	25
6.1	General	25
6.2	Single Qualification	25
6.3	Multiple Qualification	26
6.4	Visual Examination	28
6.5	Destructive Testing	29
6.6	Nondestructive Testing (NDT)—Butt Welds Only	30
6.7	Retesting	30
6.8	Records	30
7	Design and Preparation of a Joint for Production Welding	31
7.1	General	31
7.2	Alignment	31
7.3	Use of Lineup Clamp for Butt Welds	31
7.4	Bevel	31
7.5	Weather Conditions	31
7.6	Clearance	31
7.7	Cleaning Between Beads	32
7.8	Position Welding	32
7.9	Roll Welding	32
7.10	Identification of Welds	32
7.11	Preheat and PWHT	32
8	Inspection and Testing of Production Welds	33
8.1	Rights of Inspection	33
8.2	Methods of Inspection	33
8.3	Qualification of Inspection Personnel	33

Contents

	Page
8.4 Certification of NDT Personnel	33
9 Acceptance Standards for NDT	34
9.1 General	34
9.2 Rights of Rejection	34
9.3 Radiographic Testing	34
9.4 Magnetic Particle Testing	41
9.5 Liquid Penetrant Testing	42
9.6 Ultrasonic Testing	43
9.7 Visual Acceptance Standards for Undercutting	45
10 Repair and Removal of Weld Defects	45
10.1 General	45
10.2 Authorization for Repair	45
10.3 Repair Procedure	47
10.4 Repair Welder Qualification	53
10.5 Supervision	54
10.6 Acceptance Criteria	54
11 Procedures for NDT	55
11.1 Radiographic Test Methods	55
11.2 Magnetic Particle Test Method	60
11.3 Liquid Penetrant Test Method	60
11.4 Ultrasonic Test Methods	60
12 Mechanized Welding with Filler Metal Additions	66
12.1 Acceptable Processes	66
12.2 Procedure Qualification	66
12.3 Record	66
12.4 Welding Procedure Specification	66
12.5 Essential Variables	68
12.6 Qualification of Welding Equipment and Operators	70
12.7 Records of Qualified Operators	71
12.8 Inspection and Testing of Production Welds	71
12.9 Acceptance Standards for NDT	71
12.10 Repair and Removal of Defects	71
12.11 Radiographic Testing	71
12.12 Ultrasonic Testing	71
13 Automatic Welding Without Filler Metal Additions	72
13.1 Acceptable Processes	72
13.2 Procedure Qualification	72
13.3 Record	76
13.4 Welding Procedure Specification	76
13.5 Essential Variables	76
13.6 Qualification of Equipment and Operators	77
13.7 Records of Qualified Operators	77
13.8 Quality Assurance of Production Welds	77

Contents

	Page
13.9 Acceptance Standards for NDT	78
13.10 Repair and Removal of Defects	78
13.11 Radiographic Procedure	79
Annex A (normative) Alternative Acceptance Standards for Girth Welds	80
Annex B (normative) In-service Welding	102
Annex C (normative) Requests for Interpretation and Request for Revision to the Document	117
Figures	
1 Sample Welding Procedure Specification Form	10
2 Sample Coupon Test Report	11
3 Location of Test Butt Weld Specimens for Procedure Qualification Test	17
4 Tension Test Specimen	19
5 Nick Break Test Specimen	20
6 Dimensioning of Imperfections in Exposed Weld Surfaces	21
7 Root and Face Bend Test Specimen: Wall Thicknesses Less Than or Equal to 0.500 in. (12.7 mm) ...	21
8 Jig for Guided-bend Tests	22
9 Side Bend Test Specimen: Wall Thicknesses Greater than 0.500 in. (12.7 mm)	23
10 Location of Nick Break Test Specimens: Fillet Weld Procedure and Welder Qualification Test Welds	24
11 Location of Nick Break Test Specimens: Fillet Weld Procedure and Welder Qualification Test Welds, Including Size-to-size Branch Connection Welder Qualification Test	24
12 Location of Test Butt Weld Specimens for Welder Qualification Test	27
13 Inadequate Penetration Without High-low	34
14 Inadequate Penetration Due to High-low	35
15 Inadequate Cross Penetration	35
16 Incomplete Fusion at Root of Bead or Top of Joint	36
17 Incomplete Fusion Due to Cold Lap	36
18 Internal Concavity	36
19 Maximum Distribution of Gas Pockets: Wall Thickness (<i>t</i>) Less Than or Equal to 0.500 in. (12.7 mm)	39
20 Maximum Distribution of Gas Pockets: Wall Thickness (<i>t</i>) Greater Than 0.500 in. (12.7 mm)	40
21 Hardness Locations for Full Thickness Repair Procedure Qualification	50
22 Hardness Locations for Partial Thickness Repair Procedure Qualification at Weld Centerline	51
23 Hardness Locations for Cover Pass Repair Procedure at Weld Centerline	51
24 Hardness Location for Back Weld Repair or Internal Partial Thickness Repair Procedure at Weld Centerline	52
25 Hardness Locations for Cover Pass Repair Procedure at Fusion Line	52
26 Hardness Locations for Partial Thickness Repair at Fusion Line	52
27 Reference Block for Manual Ultrasonic Testing	64
28 Establishing Distance, Refracted Angle, and Velocity	64
29 Transfer Procedure	65
30 Location of Test Butt Weld Specimens for Flash Weld Procedure Qualification Test: Outside Diameter Greater Than 18 in. (457 mm) but Less Than or Equal to 24 in. (610 mm)	72
31 Location of Test Butt Weld Specimens for Flash Weld Procedure Qualification Test: Outside Diameter Greater Than 24 in. (610 mm) but Less Than or Equal to 30 in. (762 mm)	73
32 Location of Test Butt Weld Specimens for Flash Weld Procedure Qualification Test: Outside Diameter Greater Than 30 in. (762 mm)	73

Contents

Page

33	Two-in. Nick Break Test Specimen	75
A.1	Top View (Width in Circumferential Direction) of the Tensile Test Specimen	86
A.2	Charpy Specimen and V-notch Location for the HAZ Impact Testing.	87
A.3	Orientation of CTOD Test Specimen	88
A.4	Machining Objective for CTOD Test Specimen with Respect to Pipe Wall.	88
A.5	Location of Notch for Weld Metal Specimen	89
A.6	Location of Notch for Heat-affected Zone Specimen	89
A.7	Option 1 Imperfection Limits for $CTOD \geq 0.010$ in. (0.25 mm)	91
A.8	Option 1 Imperfection Limits for 0.004 in. (0.10 mm) $\leq CTOD < 0.010$ in. (0.25 mm)	92
A.9	Allowable Imperfection Size Curves Before and After Height Adjustment	94
A.10	Schematic Overview of the Option 2 Procedure	95
A.11	Criteria for Evaluation of Imperfection Interaction	101
B.1	Examples of Typical Temper Bead Deposition Sequences	103
B.2	Suggested Procedure and Welder Qualification Test Assembly	105
B.3	Suggested Location of Test Specimens for Sleeve and Branch Welds	107
B.4	Suggested Location of Test Specimens for Weld Deposition Repair	108
B.5	Macro Test Specimen—In-service Welds	109
B.6	Face Bend Test Specimen	110
B.7	Reinforcing Pad	112
B.8	Reinforcing Saddle	113
B.9	Encirclement Sleeve	113
B.10	Encirclement Tee.	114
B.11	Encirclement Sleeve and Saddle	114
B.12	Encirclement Saddle.	115

Tables

1	Filler Metal Groups	15
2	Type and Number of Test Specimens for Procedure Qualification Test.	18
3	Type and Number of Butt Weld Test Specimens per Welder for Welder Qualification Test and Destructive Testing of Production Welds.	30
4	Maximum Dimensions of Undercutting	45
5	Type and Number of Butt Weld Test Specimens per Repair Type for Repair Procedure Qualification.	48
6	Repair Weld Maximum Hardness Values, HV10.	53
7	Type and Number of Butt Weld Test Specimens per Repair Type for Repair Welder Qualification	54
8	Weld Thickness vs Diameter of ASTM E747 Wire Type IQI	58
9	Weld Thickness vs Diameter of ISO Wire Type IQI	58
10	Type and Number of Test Specimens for Procedure Qualification Test (Flash Weld Only)	74
A.1	Allowed Range of Variation from the Targeted Mean Values for a Lot Defined by Controlled Chemical Composition	84
A.2	Initial Allowable Imperfection Size for $P_f = 0.825$	93
A.3	Example Acceptance Table	94
A.4	Acceptance Limits for Buried Volumetric Imperfections	99
A.5	Acceptable Limits for Unrepaired Arc Burns.	100
B.1	Type and Number of Specimens—In-service Welding Procedure Qualification Test.	109
B.2	Type and Number of Test Specimens for Longitudinal Seam Welds—Welder Qualification Test.	111

Welding of Pipelines and Related Facilities

1 Scope

This standard covers the gas and arc welding of butt, fillet, and socket welds in carbon and low-alloy steel piping used in the compression, pumping, and transmission of crude petroleum, petroleum products, fuel gases, carbon dioxide, nitrogen, and where applicable, covers welding on distribution systems. It applies to both new construction and in-service welding. The welding may be done by a shielded metal arc welding, submerged arc welding, gas tungsten arc welding, gas metal arc welding, flux-cored arc welding, plasma arc welding, oxyacetylene welding, or flash butt-welding process or by a combination of these processes using a manual, semiautomatic, mechanized, or automatic welding technique or a combination of these techniques. The welds may be produced by position or roll welding or by a combination of position and roll welding.

This standard also covers the procedures for radiographic, magnetic particle, liquid penetrant, and ultrasonic testing, as well as the acceptance standards to be applied to production welds tested to destruction or inspected by radiographic, magnetic particle, liquid penetrant, ultrasonic, and visual testing methods.

The values stated in either U.S. customary units (USC) units or metric units (SI) are to be regarded separately as standard. Each system is to be used independently of the other, without combining values in any way.

The figures depicted in this standard are not drawn to scale.

It is intended that all work performed in accordance with this standard meets or exceeds the requirements of this standard.

While this standard is comprehensive, it may not address all issues that may arise. The absence of guidance or requirements is not to be considered prohibitive to a particular activity or approach that is based upon sound engineering judgment. For example, other industry standards, reliable engineering tests and analyses, or established industry practices may provide useful reference to establish sound engineering judgment.

2 Normative References

The following referenced documents are indispensable for the application of this document. For dated references, only the edition cited applies. For undated references, the latest edition of the referenced document (including any amendments) applies.

API Specification 5L, *Specification for Line Pipe*

API Recommended Practice 2201, *Safe Hot Tapping Practices in the Petroleum and Petrochemical Industries*

ASNT ACCP ¹, *ASNT Central Certification Program*

ASNT SNT-TC-1A, *Personnel Qualification and Certification in Nondestructive Testing*

ASTM A370 ², *Standard Test Methods and Definitions for Mechanical Testing of Steel Products*

ASTM E23, *Standard Test Methods for Notched Bar Impact Testing of Metallic Materials*

ASTM E164, *Standard Practice for Contact Ultrasonic Testing of Weldments*

ASTM E165, *Standard Test Method for Liquid Penetrant Examination*

¹ American Society for Nondestructive Testing, 1711 Arlingate Lane, P.O. Box 28518, Columbus, Ohio 43228, www.asnt.org.

² ASTM International, 100 Barr Harbor Drive, West Conshohocken, Pennsylvania 19428, www.astm.org.

ASTM E384, *Standard Test Method for Knoop and Vickers Hardness of Materials*

ASTM E709, *Standard Guide for Magnetic Particle Testing*

ASTM E747, *Standard Practice for Design, Manufacture and Material Grouping Classification of Wire Image Quality Indicators (IQI) Used for Radiology*

AWS A3.0³, *Standard Welding Terms and Definitions*

AWS A5.1, *Specification for Carbon Steel Electrodes for Shielded Metal Arc Welding*

AWS A5.2, *Specification for Carbon and Low Alloy Steel Rods for Oxyfuel Gas Welding*

AWS A5.5, *Specification for Low-Alloy Steel Electrodes for Shielded Metal Arc Welding*

AWS A5.17, *Specification for Carbon Steel Electrodes and Fluxes for Submerged Arc Welding*

AWS A5.18, *Specification for Carbon Steel Electrodes and Rods for Gas Shielded Arc Welding*

AWS A5.20, *Specification for Carbon Steel Electrodes for Flux Cored Arc Welding*

AWS A5.23, *Specification for Low-Alloy Steel Electrodes and Fluxes for Submerged Arc Welding*

AWS A5.28, *Specification for Low-Alloy Steel Electrodes and Rods for Gas Shielded Arc Welding*

AWS A5.29, *Specification for Low-Alloy Steel Electrodes for Flux Cored Arc Welding*

BSI BS EN ISO 15653:2010⁴, *Metallic Materials. Method of Test for the Determination of Quasistatic Fracture Toughness of Welds*

BSI BS 7910:2005, *Guide to Methods for Assessing the Acceptability of Flaws in Metallic Structures*

ISO 19232-1⁵, *Non-destructive testing—Image quality of radiographs—Part 1: Image quality indicators (wire type)—Determination of image quality value*

NACE MR0175:2005⁶, *Sulfide Stress Cracking Resistant Metallic Materials for Oil Field Equipment*

3 Terms, Definitions, Acronyms, and Abbreviations

3.1 Terms and Definitions

For the purposes of this standard, the welding terms and definitions as defined in AWS A3.0 shall apply, with the additions and modifications identified as follows.

3.1.1

automatic welding

Arc welding with equipment that performs the entire welding operation without manual manipulation of the arc or electrode other than guiding or tracking and without a manual welding skill requirement of the operator.

³ American Welding Society, 550 NW LeJeune Road, Miami, Florida 33126, www.aws.org.

⁴ British Standards Institution, Chiswick High Road, London W4 4AL, United Kingdom, www.bsi-global.com.

⁵ International Organization for Standardization, 1, ch. de la Voie-Creuse, Case postale 56, CH-1211 Geneva 20, Switzerland, www.iso.org.

⁶ NACE International (formerly the National Association of Corrosion Engineers), 1440 South Creek Drive, Houston, Texas 77218-8340, www.nace.org.

3.1.2**back weld repair**

Repair weld made at the back side of a groove weld.

3.1.3**branch weld**

Completed groove and/or fillet weld joining a set-on or set-in branch pipe or a set-on or set-in branch fitting to a run pipe.

3.1.4**company**

Owner company or the engineering agency in charge of construction.

NOTE A company may act through an inspector or another authorized representative.

3.1.5**contractor**

That which includes the primary contractor and any subcontractors engaged in work covered by this standard.

3.1.6**cover pass repair**

Repair to the weld face located and contained within the external reinforcement, including external undercut.

3.1.7**defect**

Imperfection of sufficient magnitude to warrant rejection based on the acceptance criteria in this standard.

3.1.8**double repair**

Second repair in a previously repaired area of a completed weld; typically referred to as a "repair of a repair" or a "re-repair."

3.1.9**full thickness repair**

Repair weld originating from the weld face that penetrates completely through the weld thickness.

3.1.10**grinding**

Mechanical means to remove weld metal using abrasive methods.

3.1.11**imperfection**

Discontinuity or irregularity that is detectable by methods outlined in this standard.

3.1.12**indication**

Evidence obtained by nondestructive testing.

3.1.13**internal concavity****IC**

Bead that is properly fused to and completely penetrates the pipe wall thickness along both sides of the bevel but whose center is somewhat below the inside surface of the pipe wall.

NOTE The magnitude of concavity is the perpendicular distance between an axial extension of the pipe wall surface and the lowest point on the weld bead surface.

3.1.14**mechanized welding**

Process where parameters and torch guidance are controlled mechanically or electronically but may be manually varied during welding to maintain the specified welding conditions.

3.1.15**multiple repairs**

More than one individual repair area location in a completed weld.

3.1.16**partial thickness repair**

Repair weld originating from the weld face or root bead surface extending into the weld but does not completely penetrate through the weld thickness.

3.1.17**position welding**

Welding in which the pipe or assembly is not rotating while the weld is being deposited.

3.1.18**qualified welder**

Welder who has demonstrated the ability to produce welds that meet the requirements of Section 5, Section 6, or Section 10 of this standard.

3.1.19**qualified welding procedure specification**

Tested and proven detailed method by which sound welds with suitable mechanical properties can be produced.

3.1.20**radiographer**

Person who performs radiographic operations.

3.1.21**repair**

Any grinding or welding on a completed weld to correct an individual defect or accumulation of defects in the weld that has been rejected by visual or nondestructive testing in accordance with acceptance criteria in this standard.

3.1.22**repair area**

One individual repair location in a completed weld that may include a single defect or accumulation of defects.

3.1.23**repair procedure**

Tested and proven detailed method by which sound repairs with suitable mechanical properties can be produced.

3.1.24**repair weld**

Weld made to repair a defect (or defects) found in a completed weld.

3.1.25**rework**

During the welding or after the weld has been completed, the removal of an imperfection that requires grinding and/or welding that is performed prior to visual or nondestructive testing of a completed weld.

NOTE Rework is not a repair.

3.1.26**roll welding**

Welding in which the pipe or assembly is rotated while the weld metal is being deposited at or near the top center.

3.1.27**root bead**

First or stringer bead that initially joins two sections of pipe, a section of pipe to a fitting, or two fittings.

3.1.28**semiautomatic welding**

Arc welding with equipment that controls only the filler metal feed. The advance of the welding is manually controlled.

3.1.29**stacked defects**

Individual imperfections aligned in the radial (through thickness) direction, at the same circumferential location, and exceed the acceptance standards.

3.1.30**weld**

Completed weld joining two sections of pipe, a section of pipe to a fitting, or two fittings.

3.1.31**welder**

Person who makes a weld.

3.2 Acronyms and Abbreviations

For the purposes of this standard, the following acronyms and abbreviations apply.

<i>A</i>	welding current (amp)
<i>a</i>	imperfection height (in. or mm)
AC	alternating current
AI	accumulation of imperfections
BT	burn-through
C	carbon
<i>c</i>	imperfection half length (in. or mm)
CE	carbon equivalent
CO ₂	carbon dioxide
CP	cluster porosity
Cr	chromium
CTOD	crack tip opening displacement
Cu	copper
CVN	Charpy V-Notch
<i>D</i>	pipe outer diameter (in. or mm)
DAC	distance amplitude correction
DC	direct current
<i>d_n</i>	<i>J</i> integral to CTOD conversion factor (unitless)
DWE	double-wall exposure

DWV	double-wall viewing
D/t	pipe diameter-to-wall thickness ratio
E	Young's modulus (ksi or MPa)
ECA	engineering critical assessment
ESI	elongated slag inclusion
EU	undercutting adjacent to the cover pass
EW	electric resistance or electric induction weld
FAC	failure assessment curve
FAD	failure assessment diagram
HAZ	heat-affected zone
HB	hollow bead porosity
H ₂ S	hydrogen sulfide
i	number i th cyclic stress, from 1 to k
IC	internal concavity
ICP	inadequate cross penetration
ID	inside diameter
IF	incomplete fusion
IFD	incomplete fusion due to cold lap
IP	inadequate penetration without high-low
IPD	inadequate penetration due to high-low
IQI	image quality indicator
ISI	isolated slag inclusion
IU	undercutting adjacent to root pass
J	heat input (joules per in.)
J_e	elastic part of J integral (ksi in. or MPa mm)
k	total number of cyclic stress levels
K_I	stress intensity factor [ksi (in.) ^{1/2} or MPa (mm) ^{1/2}]
K_r	toughness ratio in FAD format (unitless)
LB	linear buried
L_r	stress ratio in FAD format (unitless)
L_r^{cutoff}	cutoff stress ratio in FAD format (unitless).
LS	linear surface
K_r	toughness ratio
Mn	manganese
Mo	molybdenum
MPS	manufacturing procedure specification
NDT	nondestructive testing
n	strain hardening exponent (unitless)
Ni	nickel
N_i	number of cycles at the i th cyclic stress level

OD	outside diameter
P_r	normalized applied stress or load level, $P_r = \sigma_a / \sigma_f$ (unitless)
PWHT	postweld heat treatment
S	welding arc speed (in. per minute)
S^*	is the spectrum severity
SAWH	submerged-arc helical weld
SAWL	submerged-arc longitudinal weld
SCC	stress corrosion cracking
SMTS	specified minimum tensile strength
SMYS	specified minimum yield strength
S_r	stress ratio
SWE	single-wall exposure
SWV	single-wall viewing
t	specified pipe wall thickness (in. or mm)
T	transverse
TCG	time-corrected gain
V	vanadium
V	welding arc voltage (volt)
VC	volumetric cluster
VI	volumetric individual
VR	volumetric root
WT	wall thickness
Y/T	yield-to-tensile ratio
α	ratio of pipe diameter to wall thickness, $\alpha = D/t$ (unitless)
β	ration of imperfection length to pipe circumference, $\beta = 2c/\pi D$, (unitless)
$\Delta\sigma_i$	i th cyclic stress range, in kips per in. ² (ksi)
δ_e	elastic part of CTOD (in. or mm)
δ_{mat}	CTOD toughness (in. or mm)
ε_t	uniform strain (unitless)
η	ratio of imperfection height to pipe wall thickness, $\eta = a/t$, (unitless)
ν	Poisson's ratio (unitless)
π	pi
σ_a	maximum axial design stress (ksi or MPa)
σ_c	plastic collapse stress (ksi or MPa)
σ_f	flow stress of the pipe material (ksi or MPa)
σ_t, T	ultimate tensile strength of the pipe material (ksi or MPa)
σ_y, Y	specified minimum yield strength of the pipe material, or SMYS, (ksi or MPa)

4 Specifications

4.1 Equipment

Welding equipment, both gas and arc, shall be of a size and type suitable for the work and shall be maintained in a condition that ensures acceptable welds, continuity of operation, and safety of personnel. Arc welding equipment shall be operated within the amperage and voltage ranges given in the qualified welding procedure specification. Gas welding equipment shall be operated with the flame characteristics and tip sizes given in the qualified welding procedure specification. Equipment that does not meet these requirements shall be repaired or replaced.

4.2 Materials

4.2.1 Pipe and Piping Components

This standard applies to the welding of pipe and piping components that conform to material and product specifications including, but not limited to:

- a) API specifications,
- b) ASME International specifications,
- c) ASTM International specifications,
- d) Manufacturers Standardization Society (MSS) specifications,
- e) American National Standards Institute (ANSI) specifications.

This standard also applies to materials with chemical and mechanical properties that comply with one of the specifications listed in Items a) through e) above, even though the material is not manufactured in accordance with the specification.

4.2.2 Filler Metals and Fluxes

4.2.2.1 Types

All filler metals and fluxes shall conform to one of the following, except as provided below:

- a) AWS A5.1,
- b) AWS A5.2,
- c) AWS A5.5,
- d) AWS A5.17,
- e) AWS A5.18,
- f) AWS A5.20,
- g) AWS A5.23,
- h) AWS A5.28,
- i) AWS A5.29.

Filler metals and fluxes that do not conform to the specifications above may be used provided the welding procedure specifications involving their use are qualified.

4.2.2.2 Storage and Handling

Filler metals and fluxes shall be stored and handled to avoid damage to them and to the containers in which they are shipped. Filler metals and fluxes in opened containers shall be protected from deterioration, and filler metals that are coated shall be protected from excessive changes in moisture. Filler metals and fluxes that show signs of damage or deterioration shall not be used.

4.2.3 Shielding Gases

4.2.3.1 Types

Atmospheres for shielding an arc are of several types and may consist of inert gases, active gases, or mixtures of inert and active gases. The purity and dryness of these atmospheres have great influence on welding and should be of values suitable for the process and the materials to be welded. The shielding atmosphere to be used shall be qualified for the material and the welding process.

4.2.3.2 Storage and Handling

Shielding gases shall be kept in the containers in which they are supplied, and the containers shall be stored away from extremes of temperature. Gases shall not be field intermixed in their containers. Gases of questionable purity and those in containers that show signs of damage shall not be used.

5 Qualification of Welding Procedures with Filler Metal Additions

5.1 Procedure Qualification

This section applies to the qualification of welding procedures using manual welding and semiautomatic welding using filler metal additions. Section 12 applies to the qualification of welding procedures using mechanized welding with filler metal additions. Section 13 applies to the qualification of welding procedures for automatic welding without filler metal additions. When a welding procedure specification uses a combination of manual/semiautomatic and mechanized welding, the requirements of Section 5 and Section 12 apply to their portions of the welding procedure specification.

Before production welding is started, a detailed welding procedure specification shall be established and qualified to demonstrate that welds with suitable mechanical properties (such as strength, ductility, and hardness) and soundness can be made by the procedure. The quality of the welds shall be determined by destructive testing. These procedures shall be adhered to except where a change is specifically authorized by the company, as provided for in 5.4.

5.2 Record

The details of each qualified procedure shall be recorded. The record shall show complete results of the procedure qualification test. Forms similar to those shown in Figure 1 and Figure 2 should be used. The record shall be maintained as long as the procedure is in use.

5.3 Welding Procedure Specification

5.3.1 General

The welding procedure specification shall include the information specified in 5.3.2 where applicable.

5.3.2 Specification Information

5.3.2.1 Process

The specific process, method of application, or combination thereof shall be identified.

Reference: API 1104, 5.2 (The "sample form" usage does not exclude adding other details.)

WELDING PROCEDURE SPECIFICATION NUMBER _____

For _____ Welding of _____ Pipe and fittings

Process _____

Material _____

Pipe outside diameter and wall thickness _____

Joint design _____

Filler metal and number of beads _____

Electrical or flame characteristics _____

Position _____

Direction of welding _____

Number of welders _____

Time lapse between passes _____

Type and removal of lineup clamp _____

Cleaning and/or grinding _____

Preheat/postweld heat treatment _____

Shielding gas and flow rate _____

Shielding flux _____

Speed of travel _____ Plasma gas flow rate _____

Plasma gas composition _____

Plasma gas orifice size _____

Sketches and tabulations attached _____

Tested _____

Welder _____

Approved _____

Welding supervisor _____

Adopted _____

Chief engineer _____

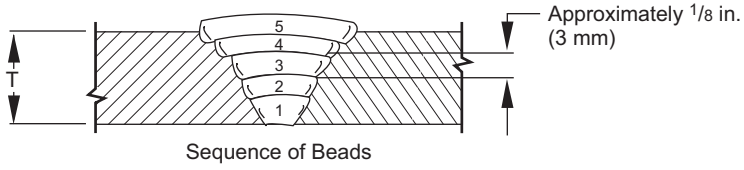
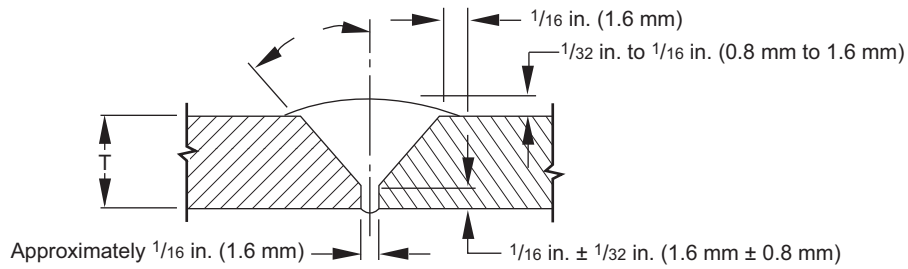

NOTE Dimensions are for example only.

ELECTRODE SIZE AND NUMBER OF BEADS

Bead Number	Electrode Size and Type	Voltage	Amperage and Polarity	Speed

Figure 1—Sample Welding Procedure Specification Form

COUPON TEST REPORT

Date _____ Test No. _____
 Location _____
 State _____ Weld Position: Roll Fixed
 Welder _____ Mark _____
 Welding time _____ Time of day _____
 Mean temperature _____ Wind break used _____
 Weather conditions _____
 Voltage _____ Amperage _____
 Welding machine type _____ Welding machine size _____
 Filler metal _____
 Reinforcement size _____
 Pipe type and grade _____
 Wall thickness _____ Outside diameter _____

	1	2	3	4	5	6	7
Coupon stenciled							
Original specimen dimensions							
Original specimen area							
Maximum load							
Tensile strength							
Fracture location							

Procedure Qualifying test Qualified
 Welder Line test Disqualified

Maximum tensile _____ Minimum tensile _____ Average tensile _____
 Remarks on tensile strength tests _____
 1. _____
 2. _____
 3. _____
 4. _____
 Remarks on bend tests _____
 1. _____
 2. _____
 3. _____
 4. _____
 Remarks on nick break tests _____
 1. _____
 2. _____
 3. _____
 4. _____

Test made at _____ Date _____
 Tested by _____ Supervised by _____

NOTE Use back for additional remarks. This form can be used to report either a procedure qualification test or a welder qualification test.

Figure 2—Sample Coupon Test Report

5.3.2.2 Materials

The materials to which the procedure applies shall be identified. API 5L pipe, as well as materials that conform to other product specifications, may be grouped (see 5.4.2.2), provided that the qualification test is made on the material with the highest specified minimum yield strength (SMYS) in the group.

5.3.2.3 Diameters and Wall Thicknesses

The ranges of specified outside diameters (ODs) and specified wall thicknesses over which the procedure is applicable shall be identified. Examples of suggested groupings are shown in 6.2.2 d) and 6.2.2 e).

5.3.2.4 Joint Design

The specification shall include a sketch or sketches of the joint that show the angle of bevel, the size of the root face, and the root opening or the space between abutting members. The shape and size of fillet welds shall be shown. If a backing is used, the type shall be designated.

5.3.2.5 Filler Metal, Flux, and Number of Beads

The sizes and classification number of the filler metal and flux and the minimum number and sequence of beads shall be designated. For any filler metals with a G suffix designator only, the manufacturer and trade name shall also be designated.

5.3.2.6 Electrical Characteristics

The current and polarity shall be designated, and the range of voltage and amperage for each type and size of electrode, rod, or wire shall be shown.

5.3.2.7 Flame Characteristics

The specification shall designate whether the flame is neutral, carburizing, or oxidizing. The size of the orifice in the torch tip for each size of rod or wire shall be specified.

5.3.2.8 Position

The specification shall designate roll or position welding.

5.3.2.9 Direction of Welding

The specification shall designate whether the welding is to be performed in an uphill or downhill direction.

5.3.2.10 Time Between Passes

The maximum time between the completion of the root bead and the start of the second bead, as well as the maximum time between the completion of the second bead and the start of other beads, shall be designated.

5.3.2.11 Type and Removal of Lineup Clamp

The specification shall designate whether the lineup clamp is to be internal or external or if no clamp is required. If a clamp is used, the minimum percentage of root bead welding that shall be completed before the clamp is released shall be specified.

5.3.2.12 Cleaning and/or Grinding

The specification shall indicate whether power tools or hand tools are to be used for cleaning, grinding, or both.

5.3.2.13 Preheat and Postweld Heat Treatment (PWHT)

Preheat and PWHT shall be as follows:

- a) for preheat, the methods, minimum temperature at the start of the weld, and minimum ambient temperature below which preheat is required shall be specified;
- b) for PWHT, the methods, minimum and maximum temperature, time at temperature, and temperature control methods for PWHT shall be specified.

5.3.2.14 Shielding Gas and Flow Rate

The composition of the shielding gas and the range of flow rates shall be designated.

5.3.2.15 Shielding Flux

The type of shielding flux shall be designated.

5.3.2.16 Speed of Travel

The range for speed of travel, in in. (mm) per minute, shall be specified for each pass.

5.3.2.17 Method of Cooling After Welding

If forced cooling is to be used, the specification shall designate the type of cooling after welding, such as forced cooling with water, as well as the maximum metal temperature at which forced cooling is applied.

5.4 Essential Variables

5.4.1 General

A welding procedure shall be reestablished as a new welding procedure specification and shall be completely requalified when any of the essential variables listed in 5.4.2 are changed. Changes other than those given in 5.4.2 may be made in the procedure without the need for requalification, provided the welding procedure specification is revised to show the changes.

5.4.2 Changes Requiring Requalification

5.4.2.1 Welding Process or Method of Application

A change from the welding process or method of application established in the welding procedure specification (see 5.3.2.1) constitutes an essential variable.

5.4.2.2 Base Material

A change in base material constitutes an essential variable. When welding materials of two separate material groups, the procedure for the higher strength group shall be used. For the purposes of this standard, all materials shall be grouped as follows.

- a) SMYS less than or equal to that of the material specified as API 5L Grade X42;

- b) SMYS greater than that of the material specified as API 5L Grade X42 but less than that of the material specified as API 5L Grade X65;
- c) for materials with a SMYS greater than or equal to that of the material specified as API 5L Grade X65, each grade shall receive a separate qualification test.

NOTE 1 The groupings specified in 5.4.2.2 do not imply that base materials or filler metals of different analyses within a group may be indiscriminately substituted for a material that was used in the qualification test without consideration of the compatibility of the base materials and filler metals from the standpoint of metallurgical and mechanical properties and requirements for preheat and PWHT.

NOTE 2 When base material with multiple grade markings is being used, the company designates, before using the material, the selected single grade to be used.

5.4.2.3 Joint Design

A major change in joint design (e.g. from V groove to U groove) constitutes an essential variable. Minor changes in the angle of bevel or the land of the welding groove are not essential variables.

5.4.2.4 Position

A change in position from roll to fixed, or vice versa, constitutes an essential variable.

5.4.2.5 Wall Thickness

A change from one specified wall thickness range to another constitutes an essential variable. Examples of suggested groupings are shown in 6.2.2 e).

5.4.2.6 Filler Metal

The following changes in filler metal constitute essential variables:

- a) a change from one filler metal group to another (see Table 1);
- b) for Groups 1 through 3 in Table 1, any change in suffix designator except within the group consisting of:
 - no suffix designator,
 - -1,
 - A1,
 - C1, C2, Ce,
 - C1L, C2L, C3L,
 - M,
 - P1, or P2;

NOTE For example, a change in suffix designator from A1 to B3, or vice versa, constitutes an essential variable. A change from A1 to C3, or vice versa, does not constitute an essential variable.

- c) for any filler metals with a G suffix designator only, a change in the manufacturer or trade name;

- d) for materials with a SMYS greater than or equal to that of the material specified as API 5L Grade X65, any change in the AWS classification of the filler metal (see 5.4.2.2).

NOTE Except as indicated items in b) and c) above, changes in filler metal within filler metal groups may be made within the material groups specified in 5.4.2.2, items a) and b).

The compatibility of the base material and the filler metal should be considered from the standpoint of mechanical properties.

5.4.2.7 Electrical Characteristics

A change from direct current (DC) electrode positive to DC electrode negative, or vice versa, or a change in current from DC to alternating current (AC), or vice versa, constitutes an essential variable.

Table 1—Filler Metal Groups

Group	AWS Specification	AWS Classification Electrode	Flux ^c
1	A5.1	E6010, E6011	
	A5.5	E7010, E7011	
2	A5.5	E8010, E8011, E9010	
3	A5.1 or A5.5	E7015, E7016, E7018	
	A5.5	E8015, E8016, E8018	
		E9018	
4 ^a	A5.17	EL8	P6XZ
		EL8K	F6X0
		EL12	F6X2
		EM5K	F7XZ
		EM12K	F7X0
		EM13K	F7X2
5 ^b		EM15K	
	A5.18	ER70S-2	
	A5.18	ER70S-6	
	A5.28	ER80S-D2	
	A5.28	ER90S-G	

Table 1—Filler Metal Groups

Group	AWS Specification	AWS Classification Electrode	Flux ^c
6	A5.2	RG60, RG65	
7	A5.20	E61T-GS ^d	
		E71T-GS ^d	
8	A5.29	E71T8-K6	
9	A5.29	E91T8-G	
NOTE Other electrodes, filler metals, and fluxes may be used but require separate procedure qualification.			
^a Any combination of flux and electrode in Group 4 may be used to qualify a procedure. The combination is identified by its complete AWS classification number, such as F7A0-EL12 or F6A2-EM12K. Only substitutions that result in the same AWS classification number are permitted without requalification. ^b A shielding gas (see 5.4.2.10) is required for use with the electrodes in Group 5. ^c In the flux designation, the X can be either an A or P for as-welded or postweld heat treated. ^d For root pass welding only.			

5.4.2.8 Time Between Passes

An increase in the maximum time between completion of the root bead and the start of the second bead constitutes an essential variable.

5.4.2.9 Direction of Welding

A change in the direction of welding from vertical downhill to vertical uphill, or vice versa, constitutes an essential variable.

5.4.2.10 Shielding Gas and Flow Rate

A change from one shielding gas to another or from one mixture of gases to another constitutes an essential variable. An increase or decrease in the range of flow rates for the shielding gas greater than 20 % of the nominal flow rate also constitutes an essential variable.

5.4.2.11 Shielding Flux

Refer to Table 1, Footnote a, for changes in shielding flux that constitute essential variables.

5.4.2.12 Speed of Travel

A change in the range for speed of travel constitutes an essential variable.

5.4.2.13 Preheat

A decrease in the specified minimum preheat temperature constitutes an essential variable.

5.4.2.14 PWHT

The addition of PWHT or a change from the ranges or values specified in the procedure each constitutes an essential variable.

5.5 Welding of Test Joints—Butt Welds

To weld the test joint for butt welds, two pipe nipples shall be joined, following all the details of the welding procedure specification.

5.6 Testing of Welded Joints—Butt Welds

5.6.1 Preparation

To test the butt-welded joint, test specimens shall be cut from the joint at the locations shown in Figure 3. The minimum number of test specimens and the tests to which they shall be subjected are given in Table 2. For pipe less than 2.375 in. (60.3 mm) in OD, two test welds shall be performed to obtain the required number of test specimens. The specimens shall be air cooled to ambient temperature prior to being tested. The full-section specimen shall be tested in accordance with 5.6.2.2 and shall meet the requirements of 5.6.2.3.

5.6.2 Tensile Strength Test

5.6.2.1 Preparation

The full-thickness tensile strength test specimens shall be either of the types shown in Figure 4.

- a) The standard specimens shall be prepared as shown in Figure 4 a). They may be machine cut or oxygen cut, and no other preparation is needed unless the sides are notched or are not parallel. If necessary, the specimens shall be machined so that the sides are smooth and parallel.
- b) The reduced section specimens shall be prepared as shown in Figure 4 b). The weld reinforcement may be removed.

5.6.2.2 Method

The tensile strength test specimens shall be broken under tensile load using equipment capable of measuring the load at which failure occurs. The tensile strength shall be computed by dividing the maximum load at failure by the smallest cross-sectional area of the specimen, as measured before the load is applied.

5.6.2.3 Requirements

The tensile strength of the weld, including the fusion zone of each specimen, shall be greater than or equal to the specified minimum tensile strength (SMTS) of the pipe material but need not be greater than or equal to the actual tensile strength of the material. If the specimen breaks outside the weld and fusion zone (i.e. in the parent metal) at a tensile strength not less than 95 % of that of the SMTS of the pipe material, the weld shall be accepted as meeting the requirements.

If the specimen breaks in the weld or fusion zone and the observed strength is greater than or equal to the SMTS of the pipe material and meets the soundness requirements of 5.6.3.3, the weld shall be accepted as meeting the requirements.

If the specimen breaks in the weld and below the SMTS of the pipe material, the weld shall be set aside and a new test weld shall be made.

If a specimen breaks outside of both the weld and the heat-affected zone (HAZ) at a tensile strength not less than 95 % of that of the SMTS of the pipe material, that specimen shall be accepted as meeting the test requirements.

Any specimen that fails due to improper specimen preparation or testing may be replaced and retested.

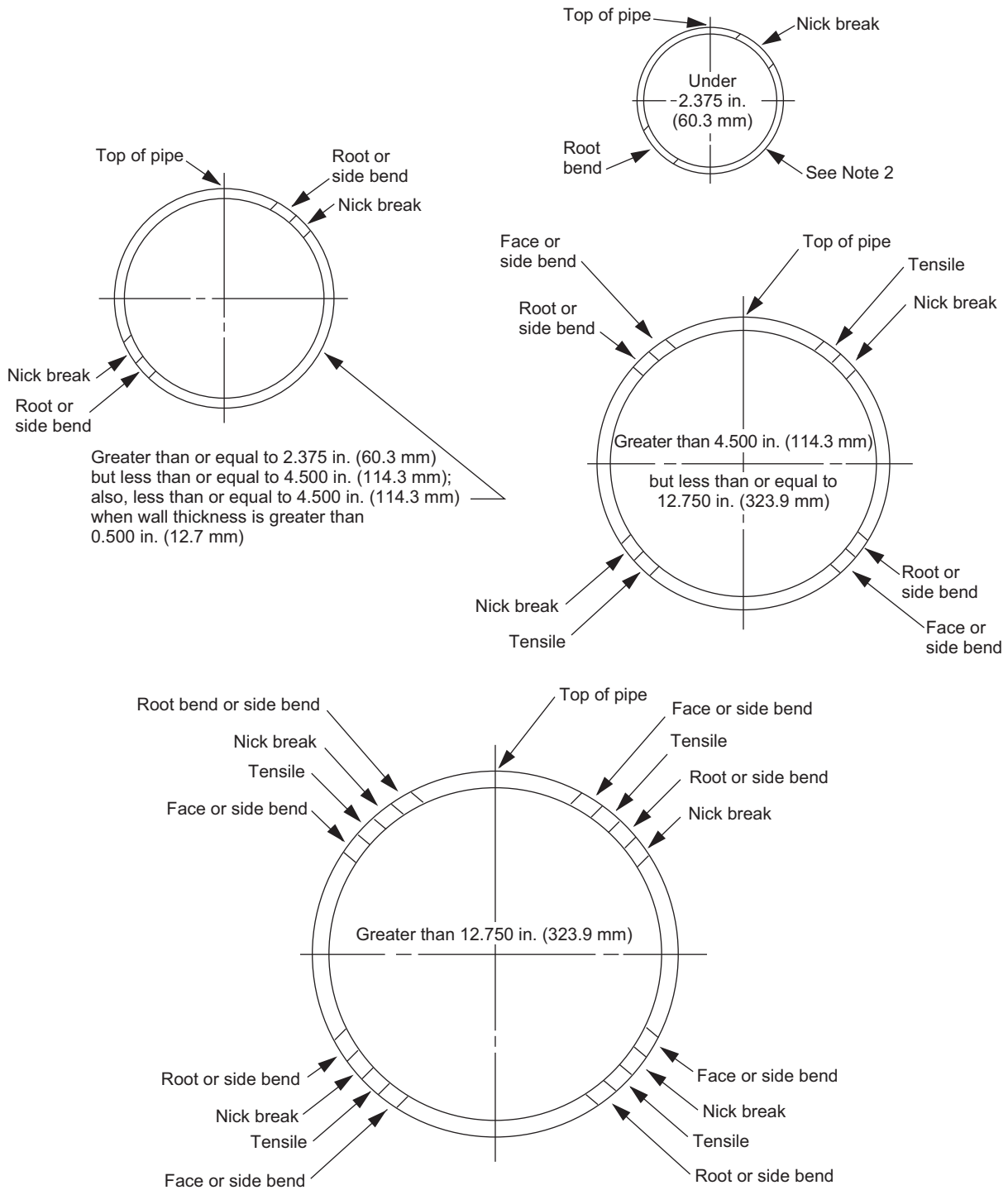

NOTE 1 At the company's option, the locations may be rotated, provided they are equally spaced around the pipe; however, specimens do not include the longitudinal weld.

NOTE 2 One full-section tensile specimen may be used for pipe with an outside diameter less than or equal to 1.315 in. (33.4 mm).

Figure 3—Location of Test Butt Weld Specimens for Procedure Qualification Test

Table 2—Type and Number of Test Specimens for Procedure Qualification Test

Outside Diameter of Pipe		Number of Specimens					
in.	mm	Tensile Strength	Nick Break	Root Bend	Face Bend	Side Bend	Total
Wall Thickness ≤ 0.500 in. (12.7 mm)							
<2.375	<60.3	0 ^b	2	2	0	0	4 ^a
2.375 to 4.500	60.3 to 114.3	0 ^b	2	2	0	0	4
>4.500 to 12.750	>114.3 to 323.9	2	2	2	2	0	8
>12.750	>323.9	4	4	4	4	0	16
Wall Thickness > 0.500 in. (12.7 mm)							
≤4.500	≤114.3	0 ^b	2	0	0	2	4
>4.500 to 12.750	>114.3 to 323.9	2	2	0	0	4	8
>12.750	>323.9	4	4	0	0	8	16
^a One nick break and one root bend specimen are taken from each of two test welds, or for pipe less than or equal to 1.315 in. (33.4 mm) in diameter, one full-section tensile strength specimen is taken.							
^b For materials with SMYS's greater than the material specified as API 5L Grade X42, a minimum of one tensile test is required.							

5.6.3 Nick Break Test

5.6.3.1 Preparation

The nick break test specimens (see Figure 5, top) shall be approximately 9 in. (230 mm) long and approximately 1 in. (25 mm) wide and may be machine cut or oxygen cut. They shall be notched with a hacksaw on each side at the center of the weld, and each notch shall be approximately $\frac{1}{8}$ in. (3 mm) deep and the edges shall be smooth and parallel.

Nick break specimens prepared in this manner from welds made with certain mechanized and semiautomatic processes may fail through the pipe instead of the weld. When previous testing experience indicates that failures through the pipe can be expected, the external reinforcement may be notched to a depth of not more than $\frac{1}{16}$ in. (1.6 mm), measured from the original weld surface (see Figure 5, bottom).

At the company's option, nick break specimens for qualification of a procedure using a semiautomatic or mechanized welding process may be macroetched prior to being nicked.

5.6.3.2 Method

The nick break specimens shall be broken through the weld by any convenient method (i.e. pulling, bending, or striking). This does not exclude other testing methods. The exposed area of the fracture shall be at least $\frac{3}{4}$ in. (19 mm) wide.

5.6.3.3 Requirements

The exposed surfaces of each nick break specimen shall show complete penetration and fusion. The greatest dimension of any gas pocket shall not exceed $\frac{1}{16}$ in. (1.6 mm), and the combined area of all gas pockets shall not exceed 2 % of the exposed surface area. Slag inclusions shall not be more than $\frac{1}{32}$ in. (0.8 mm) in depth and shall not be more than $\frac{1}{8}$ in. (3 mm) or one-half the specified wall thickness in length, whichever is smaller. There shall be at least $\frac{1}{2}$ in. (13 mm) separation between adjacent slag inclusions of any size. The dimensions should be measured as shown in Figure 6. Fisheyes, as defined in AWS A3.0, are not cause for rejection.

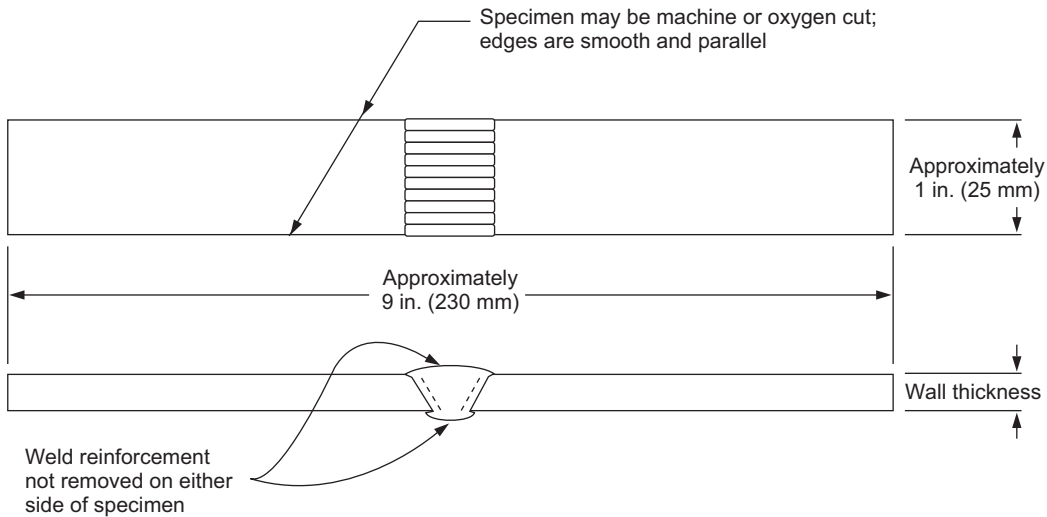

a) Tensile Strength Test Specimen

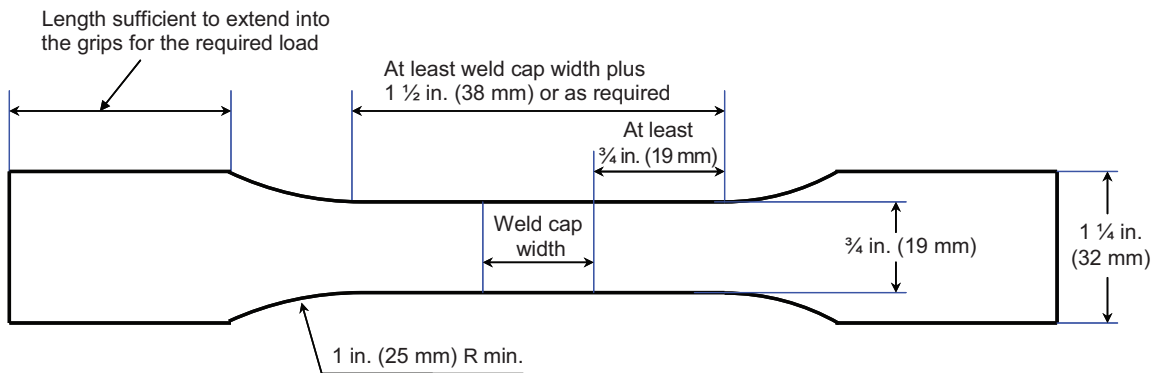

NOTE Dimensions are approximate.

b) Reduced Section Tensile Strength Test Specimen

Figure 4—Tension Test Specimen

For a test weld diameter greater than 12 ³/₄ in. (323.9 mm), if only one nick break specimen fails, then the specimen may be replaced by two additional nick break specimens from locations near to the failed specimen. If either of the replacement nick break specimens fail, the weld is considered unacceptable.

5.6.4 Root and Face Bend Test

5.6.4.1 Preparation

The root and face bend test specimens (see Figure 7) shall be approximately 9 in. (230 mm) long and approximately 1 in. (25 mm) wide, and their long edges shall be rounded. They may be machine cut or oxygen cut. The cover and root bead reinforcements shall be removed flush with the surfaces of the specimen. These surfaces shall be smooth,

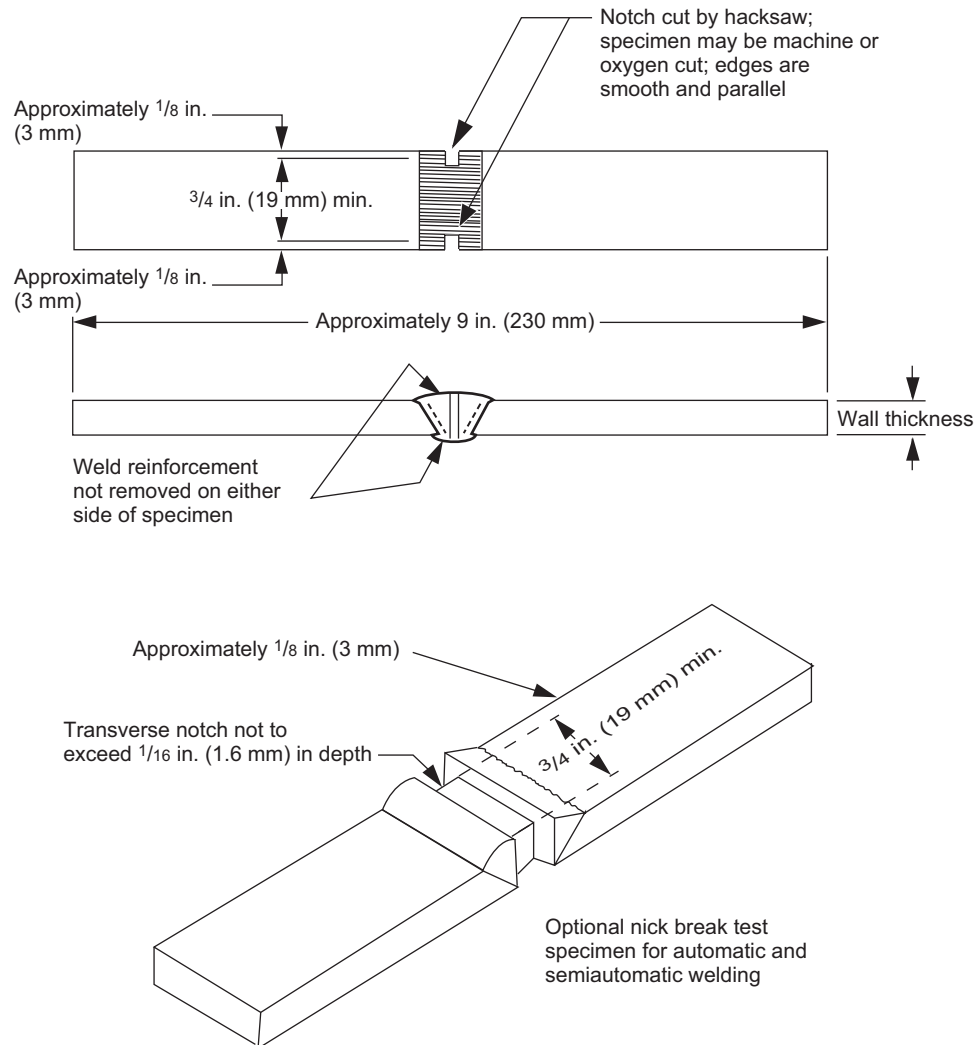

Figure 5—Nick Break Test Specimen

and any scratches that exist shall be light and transverse to the weld. The specimen shall not be flattened prior to testing.

5.6.4.2 Method

The root and face bend specimens shall be bent in a guided-bend test jig similar to that shown in Figure 8. Each specimen shall be placed on the die with the weld at midspan. Face bend specimens shall be placed with the face of the weld toward the gap, and root bend specimens shall be placed with the root of the weld toward the gap. The plunger shall be forced into the gap until the curvature of the specimen is approximately U shaped. Alternate best test fixtures with bend radii equal to or less than the radius specified in Figure 8 may be used at the discretion of the company.

5.6.4.3 Requirements

The bend test shall be considered acceptable if no crack or other imperfection exceeding $\frac{1}{8}$ in. (3 mm) or one-half the specified wall thickness, whichever is smaller, in any direction is present in the weld or between the weld and the fusion zone after bending. Cracks that originate on the outer radius of the bend along the edges of the specimen during testing and that are less than $\frac{1}{4}$ in. (6 mm), measured in any direction, shall not be considered unless obvious

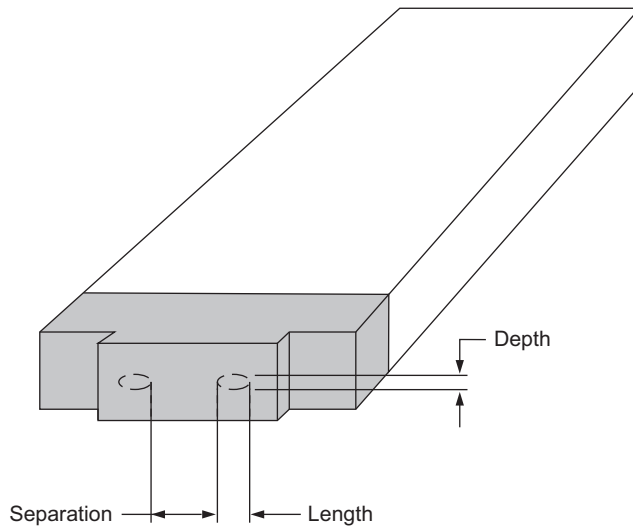

NOTE A broken nick break test specimen is shown; however, this method of dimensioning applies also to broken tensile and fillet weld test specimens.

Figure 6—Dimensioning of Imperfections in Exposed Weld Surfaces

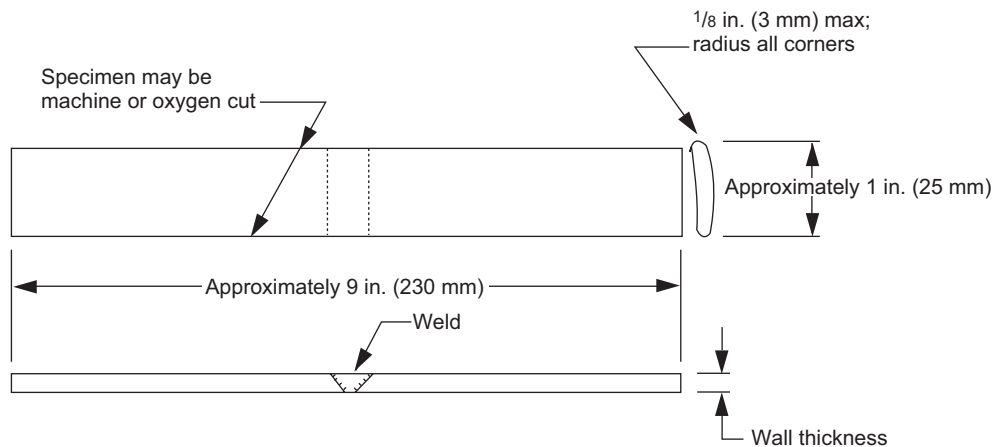

NOTE The weld reinforcement is removed from both faces and made flush with the surface of the specimen. The specimen is not flattened prior to testing.

Figure 7—Root and Face Bend Test Specimen: Wall Thicknesses Less Than or Equal to 0.500 in. (12.7 mm)

imperfections are observed. For test weld diameter greater than $12\frac{3}{4}$ in. (323.9 mm), if only one bend specimen fails, the specimen may be replaced with two additional specimens from locations adjacent to the failed specimen. If either of the replacement bend test specimens fails, the weld is considered unacceptable.

5.6.5 Side Bend Test

5.6.5.1 Preparation

The side bend test specimens (see Figure 9) shall be approximately 9 in. (230 mm) long and approximately $\frac{1}{2}$ in. (13 mm) wide, and their long edges shall be rounded. They shall be machine cut, or they may be oxygen cut to

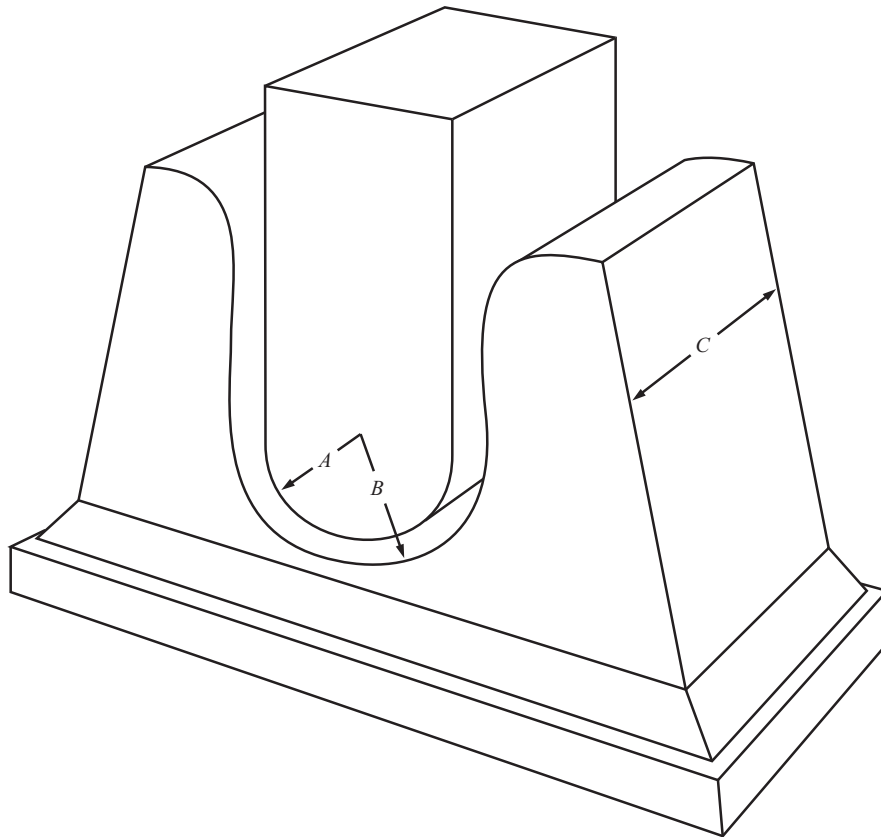

NOTE This figure is not drawn to scale. Radius of plunger, $A = 1 \frac{3}{4}$ in. (45 mm); radius of die, $B = 2 \frac{5}{16}$ in. (60 mm); width of die, $C = 2$ in. (50 mm).

Figure 8—Jig for Guided-bend Tests

approximately a $\frac{3}{4}$ in. (19 mm) width and then machined or ground to the $\frac{1}{2}$ in. (13 mm) width. The sides shall be smooth and parallel. The cover and root bead reinforcements shall be removed flush with the surfaces of the specimen.

5.6.5.2 Method

The side bend specimens shall be bent in a guided-bend test jig similar to that shown in Figure 8. Each specimen shall be placed on the die with the weld at midspan and with the face of the weld perpendicular to the gap. The plunger shall be forced into the gap until the curvature of the specimen is approximately U shaped. Alternate bend test fixtures with bend radii equal to or less than the radius specified in Figure 8 may be used at the discretion of the company.

5.6.5.3 Requirements

Each side bend specimen shall meet the root and face bend test requirements specified in 5.6.4.3. For test weld diameter greater than $12 \frac{3}{4}$ in. (323.9 mm), a single failed side bend specimen may be replaced with two additional specimens from locations adjacent to the failed specimen. If either of the replacement bend test specimens fails, the weld is considered unacceptable.

5.7 Welding of Test Joints—Fillet Welds

To weld the test joint for a fillet weld, a fillet weld shall be made to one of the configurations shown in Figure 10, following all the details of the welding procedure specification.

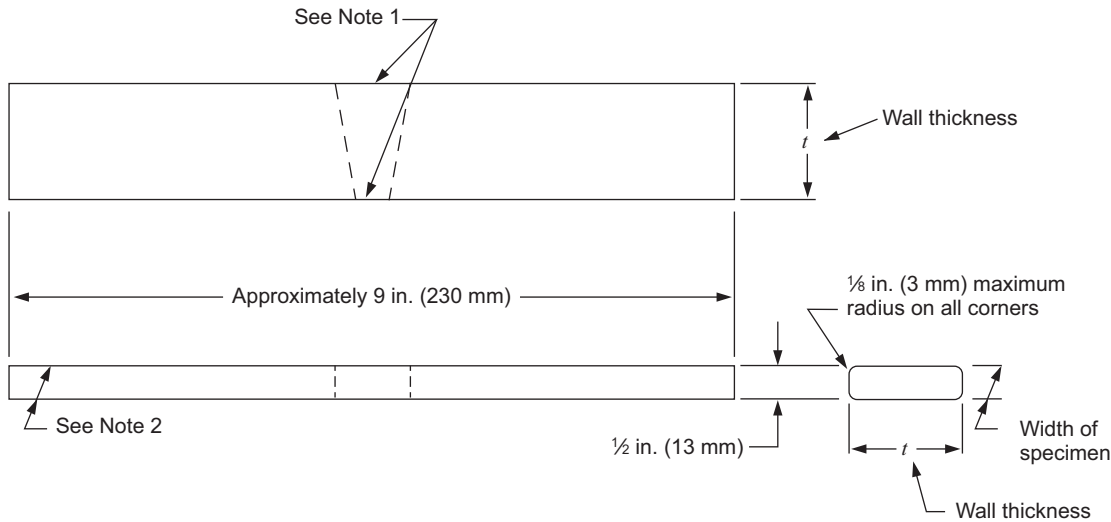

NOTE 1 The weld reinforcement is removed from both faces flush with the surface of the specimen.

NOTE 2 Specimens may be machine cut to a width of $\frac{1}{2}$ in. (13 mm), or they may be oxygen cut to a width of approximately $\frac{3}{4}$ in. (19 mm) and then machined or ground smooth to a width of $\frac{1}{2}$ in. (13 mm). Cut surfaces are smooth and parallel.

Figure 9—Side Bend Test Specimen: Wall Thicknesses Greater than 0.500 in. (12.7 mm)

5.8 Testing of Welded Joints—Fillet Welds

5.8.1 Preparation

To test the fillet-welded joint, test specimens shall be cut from the joint at the locations shown in Figure 10. At least four specimens shall be taken and prepared as shown in Figure 11. The specimens may be machine cut or oxygen cut. They should be at least 1 in. (25 mm) wide and long enough so that they can be broken in the weld. For pipes less than 2.375 in. (60.3 mm) in OD, specimens shall be cut from the same general location. It may be necessary to make two test welds to obtain the required number of test specimens; two specimens shall be removed from each of two test welds. The specimens shall be air cooled to ambient temperature prior to testing.

5.8.2 Method

The fillet weld specimens shall be broken in the weld by any convenient method.

5.8.3 Requirements

The exposed surfaces of each fillet weld specimen shall show complete penetration and fusion, and

- the greatest dimension of any gas pocket shall not exceed $\frac{1}{16}$ in. (1.6 mm);
- the combined area of all gas pockets shall not exceed 2 % of the exposed surface area;
- slag inclusions shall not be more than $\frac{1}{32}$ in. (0.8 mm) in depth and shall not be more than $\frac{1}{8}$ in. (3 mm) or one-half the specified wall thickness in length, whichever is smaller; and
- there shall be at least $\frac{1}{2}$ in. (13 mm) separation between adjacent slag inclusions.

The dimensions should be measured as shown in Figure 6.

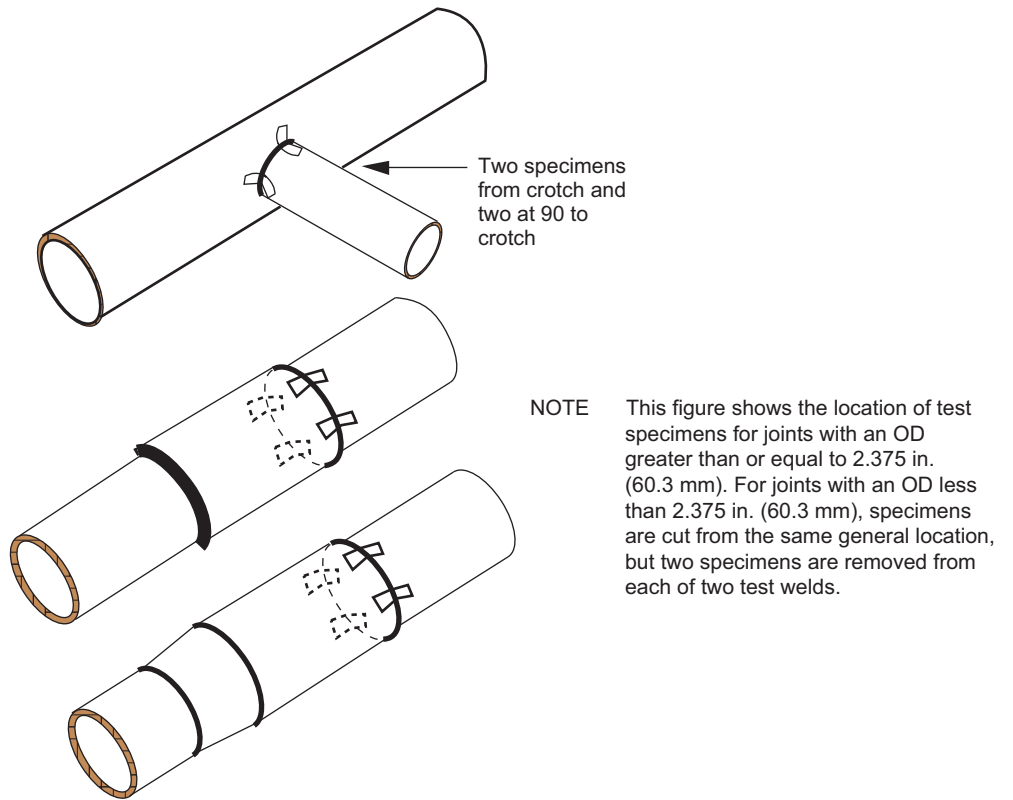

Figure 10—Location of Nick Break Test Specimens: Fillet Weld Procedure and Welder Qualification Test Welds

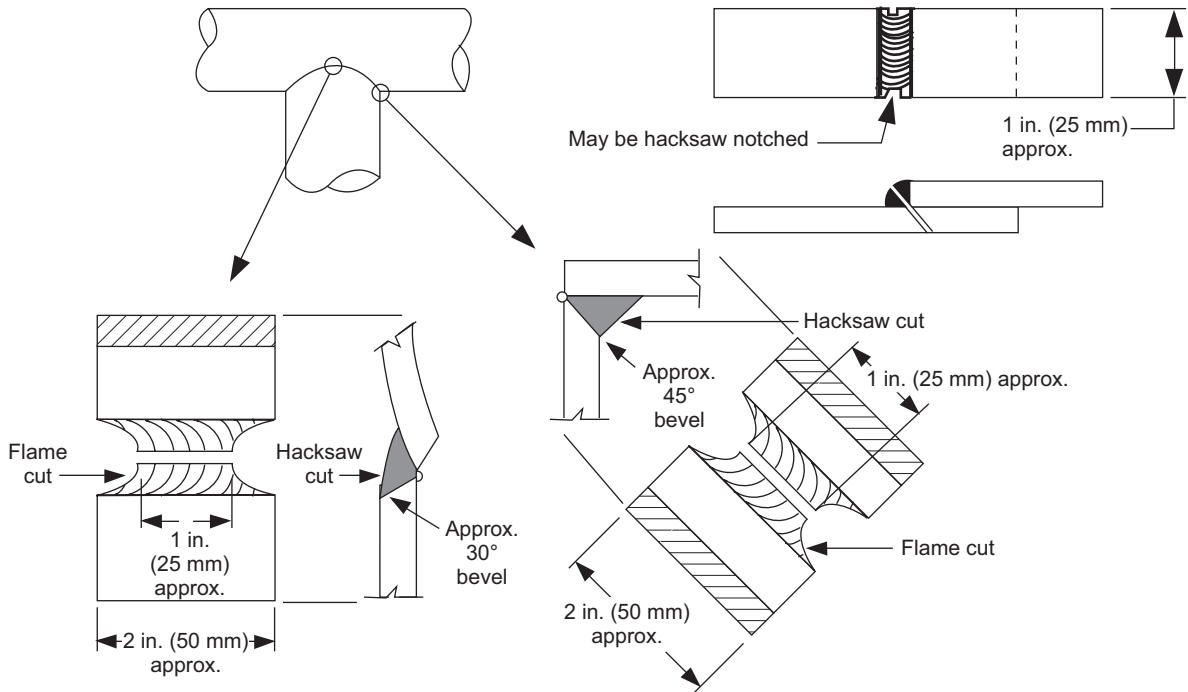

Figure 11—Location of Nick Break Test Specimens: Fillet Weld Procedure and Welder Qualification Test Welds, Including Size-to-size Branch Connection Welder Qualification Test

6 Qualification of Welders

6.1 General

The purpose of the welder qualification test is to determine the ability of welders to make sound butt or fillet welds using previously qualified procedures. Before any production welding is performed, welders shall be qualified according to the applicable requirements of 6.2 through 6.8. It is the intent of this standard that a welder who satisfactorily completes the procedure qualification test is a qualified welder, provided the number of test specimens required by 6.5 has been removed, tested, and meet the acceptance criteria of 5.6, for each welder.

Prior to starting the qualification tests, the welder shall be allowed reasonable time to adjust the welding equipment to be used. The welder shall follow the requirements of the applicable qualified welding procedure specification. The qualification of welders shall be conducted in the presence of a representative acceptable to the company.

A welder shall qualify for welding by performing a test on segments of pipe nipples or on full-size pipe nipples, as specified in 6.2.1. When segments of pipe nipples are used, they shall be supported so that typical flat, vertical, and overhead welds are produced.

The essential variables associated with procedure and welder qualifications are not identical. The essential variables for welder qualification are specified in 6.2.2 and 6.3.2.

6.2 Single Qualification

6.2.1 General

For qualification to a single weld procedure specification, a welder shall make a test weld using a qualified procedure to join pipe nipples or segments of pipe nipples. The welder shall make a butt weld in either the rolled or the fixed position. When the welder is qualifying in the fixed position, the axis of the pipe shall be horizontal, vertical, or inclined from horizontal at an angle of not more than 45°.

A welder making a single-qualification test for branch connections, fillet welds, or other similar configurations shall follow the specific welding procedure specification.

Changes in the essential variables described in 6.2.2 require requalification of the welder.

The weld shall be acceptable if it meets the requirements of 6.4 and either 6.5 or 6.6.

6.2.2 Scope

A welder who has successfully completed the qualification test described in 6.2.1 shall be qualified within the limits of the essential variables described below. If any of the following essential variables are changed, the welder shall be requalified using an applicable qualified procedure.

- a) A change from one welding process to another welding process or combination of processes, as follows:
 - 1) a change from one welding process to a different welding process; or
 - 2) a change in the combination of welding processes, unless the welder has qualified on separate qualification tests, using each of the welding processes that are to be used for the combination of welding processes.
- b) A change in the direction of welding from vertical uphill to vertical downhill or vice versa.

- c) A change of filler metal classification from Group 1 or 2 to any other group or from any Group 3 through 9 to Group 1 or 2 (see Table 1). A change of filler metal classification not listed in Table 1 to any other filler metal classification or vice versa.
- d) A change from one specified OD group to another. These groups are defined as follows:
- 1) specified OD less than 2.375 in. (60.3 mm),
 - 2) specified OD from 2.375 in. (60.3 mm) through 12.750 in. (323.9 mm),
 - 3) specified OD greater than 12.750 in. (323.9 mm).
- e) A change from one specified wall thickness group to another. These groups are defined as follows:
- 1) specified pipe wall thickness less than 0.188 in. (4.8 mm),
 - 2) specified pipe wall thickness from 0.188 in. (4.8 mm) through 0.750 in. (19.1 mm),
 - 3) specified pipe wall thickness greater than 0.750 in. (19.1 mm).
- f) A change in position from that for which the welder has already qualified (e.g. a change from rolled to fixed or a change from vertical to horizontal or vice versa). A welder who qualifies in the fixed position shall also be qualified to perform rolled welds within the essential variables qualified. A welder who qualifies on a butt weld shall also be qualified to make lap fillet welds within the essential variables qualified. A welder who successfully passes a butt weld qualification test in the fixed position with the axis inclined 45° from horizontal shall be qualified to do butt welds and lap fillet welds in all positions.
- g) A change in the joint design (e.g. the elimination of a backing strip or a change from V bevel to U bevel).

6.3 Multiple Qualification

6.3.1 General

For multiple qualification, a welder shall successfully complete the two tests described below, using qualified procedures.

For the first test, the welder shall make a butt weld in the fixed position with the axis of the pipe either horizontal or inclined from horizontal at an angle of not more than 45°. This butt weld shall be made on pipe with an OD of at least 6.625 in. (168.3 mm) and with a wall thickness of at least 0.250 in. (6.4 mm) without a backing strip. The weld shall be acceptable if it meets the requirements of 6.4 and either 6.5 or 6.6. Specimens may be removed from the test weld at the locations shown in Figure 12, or they may be selected at the relative locations shown in Figure 12 but without reference to the top of the pipe, or they may be selected from locations that are spaced equidistantly around the entire pipe circumference. The sequence of adjacent specimen types shall be identical to that shown in Figure 12 for the various pipe diameters. Specimens shall not include the longitudinal weld.

For the second test, the welder shall lay out, cut, fit, and weld a branch-on-pipe connection in which the specified diameters of the run and the branch pipes are equal. This test shall be performed with a pipe diameter of at least 6.625 in. (168.3 mm) and with a specified wall thickness of at least 0.250 in. (6.4 mm). A hole with specified diameter approximately equal to the inside diameter (ID) of the branch pipe shall be cut in the run. The weld shall be made with the run pipe axis horizontal and the branch pipe axis extending vertically downward from the run pipe.

The completed weld shall exhibit complete penetration around the entire circumference. Completed root beads shall not contain any burn-through (BT) of more than 1/4 in. (6 mm). The sum of the maximum dimensions of separate unrepaired BTs in any continuous 12 in. (300 mm) length of weld shall not exceed 1/2 in. (13 mm).

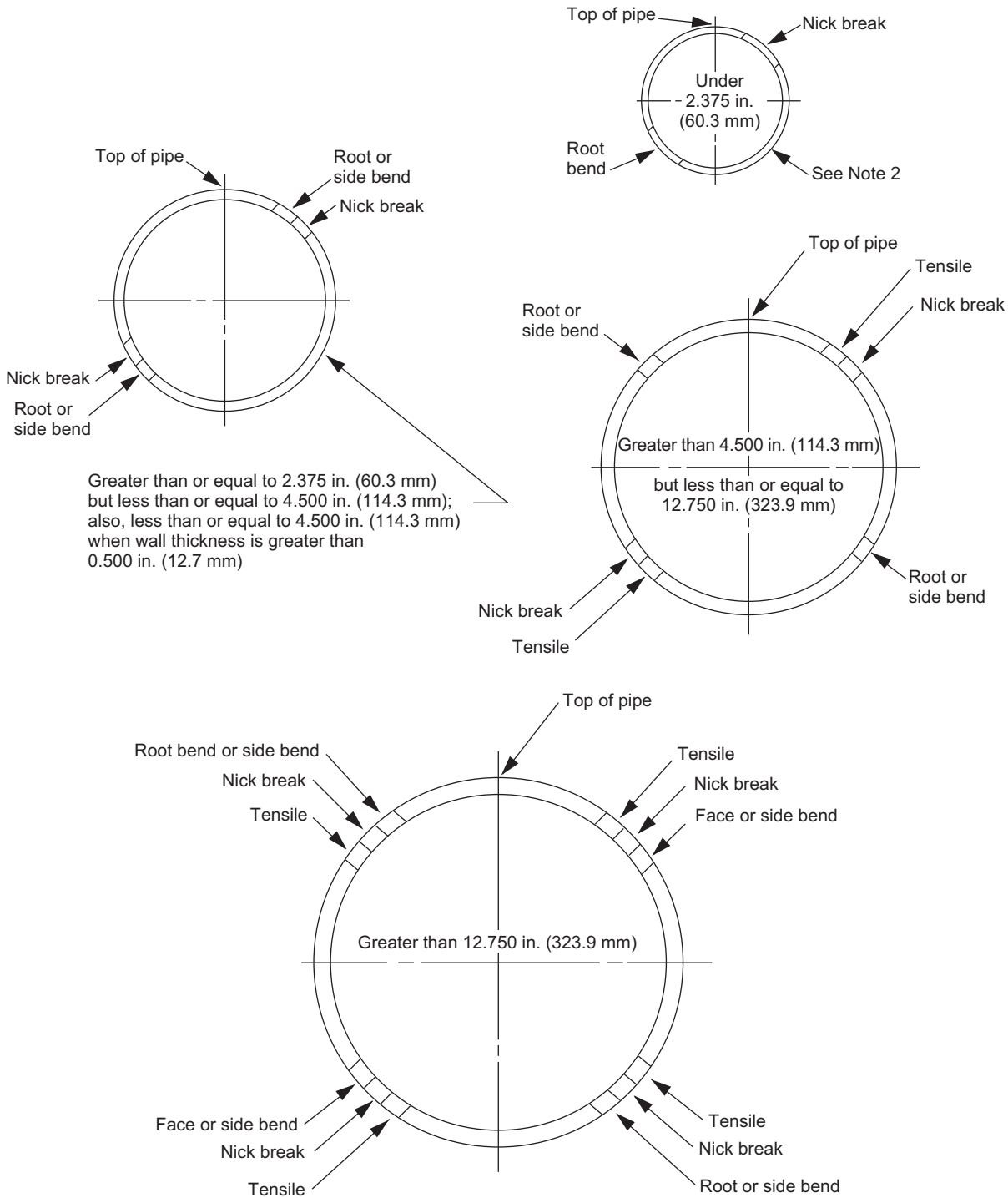

NOTE 1 At the company's option, the locations may be rotated, provided they are equally spaced around the pipe; however, specimens do not include the longitudinal weld.

NOTE 2 One full-section tensile strength specimen may be used for pipe with an OD less than or equal to 1.315 in. (33.4 mm).

Figure 12—Location of Test Butt Weld Specimens for Welder Qualification Test

Four nick break specimens shall be removed from the weld at the locations shown in Figure 10. They shall be prepared and tested in accordance with 5.8.1 and 5.8.2. The exposed surfaces shall meet the requirements of 5.8.3.

6.3.2 Scope

A welder who has successfully completed the butt weld qualification test described in 6.3.1 on pipe with an OD greater than or equal to 12.750 in. (323.9 mm) and a branch weld with pipe and branch having specified ODs greater than or equal to 12.750 in. (323.9 mm) in which the specified diameters of the run and branch pipes are equal shall be qualified to weld in all positions; on all wall thicknesses, joint designs, and fittings; and on all pipe diameters. A welder who has successfully completed the butt weld and branch weld requirements of 6.3.1 on pipe with an OD less than 12.750 in. (323.9 mm) shall be qualified to weld in all positions; on all wall thicknesses, joint designs, and fittings; and on all pipe ODs less than or equal to the OD used by the welder in the qualification tests.

If any of the following essential variables are changed in a welding procedure specification, the welder using the new procedure shall be requalified.

- a) A change from one welding process to another welding process or combination of processes, as follows:
 - 1) a change from one welding process to a different welding process; or
 - 2) a change in the combination of welding processes, unless the welder has qualified on separate qualification tests, each using the same welding process that is used for the combination of welding processes.
- b) A change in the direction of welding from vertical uphill to vertical downhill or vice versa.
- c) A change of filler metal classification from Group 1 or 2 to any other group or from any Group 3 through 9 to Group 1 or 2 (see Table 1). A change of filler metal classification not listed in Table 1 to any other filler metal classification or vice versa.

6.4 Visual Examination

For a qualification test weld to meet the requirements for visual examination, the weld shall be free from cracks, inadequate penetration, and BT, and must present a neat workman-like appearance. The depth of undercutting adjacent to the final bead on the outside of the pipe shall not be more than $\frac{1}{32}$ in. (0.8 mm) or 12.5 % of the pipe wall thickness, whichever is smaller, and there shall not be more than 2 in. (50 mm) of undercutting in any continuous 12 in. (300 mm) length of weld.

When semiautomatic or mechanized welding is used, filler wire protruding into the inside of the pipe shall be kept to a minimum.

Failure to meet the requirements of this section shall be adequate cause to eliminate additional testing.

6.5 Destructive Testing

6.5.1 Sampling of Test Butt Welds

To test butt welds, samples shall be cut from each test weld. Figure 12 shows the locations from which the specimens are to be removed if the test weld is a complete circumferential weld. If the test weld consists of segments of pipe nipples, an approximately equal number of specimens shall be removed from each segment. The total number of specimens and the tests to which each shall be submitted are shown in Table 3. The specimens shall not include the longitudinal weld. The specimens shall be air cooled to ambient temperature prior to testing. For pipe with an OD less than or equal to 1.315 in. (33.4 mm), one full-pipe section specimen may be substituted for the root bend and nick break specimens. This full-section specimen shall be tested in accordance with 5.6.2.2 and shall meet the requirements of 6.5.3.

6.5.2 Tensile Strength, Nick Break, and Bend Test Procedures for Butt Welds

The specimens shall be prepared for tensile strength, nick break, and bend tests, and the tests shall be performed as described in 5.6. However, for the purpose of welder qualification under Section 6, it is not necessary to calculate the tensile strength of the coupons. The tensile strength test may even be omitted; in which case the specimens designated for the tensile test shall be subjected to the nick break test. For qualification of welding equipment and operators under Section 12, the tensile strength test shall not be omitted and the tensile strength shall be determined.

6.5.3 Tensile Strength Test Requirements for Butt Welds

For the tensile strength test, if any of the reduced section specimens or the full section specimen breaks in the weld or at the junction of the weld and the parent material and fails to meet the soundness requirements of 5.6.3.3, the welder shall be disqualified.

6.5.4 Nick Break Test Requirements for Butt Welds

For the nick break test, if any specimen shows imperfections that exceed those allowed by 5.6.3.3, the welder shall be disqualified.

6.5.5 Bend Test Requirements for Butt Welds

For the bend tests, if any specimen shows imperfections that exceed those allowed by 5.6.4.3 or 5.6.5.3, the welder shall be disqualified. Welds in high strength pipe may not bend to the full U shape. These welds shall be considered acceptable if the specimens that crack are broken apart and their exposed surfaces meet the requirements of 5.6.3.3.

If one of the bend test specimens fails to meet these requirements and, in the company's opinion, the imperfection observed is not representative of the weld, the test specimen may be replaced by an additional specimen cut adjacent to the one that failed. The welder shall be disqualified if the additional specimen also shows imperfections that exceed the specified limits.

Table 3—Type and Number of Butt Weld Test Specimens per Welder for Welder Qualification Test and Destructive Testing of Production Welds

Outside Diameter of Pipe		Number of Specimens					
in.	mm	Tensile Strength	Nick Break	Root Bend	Face Bend	Side Bend	Total
Wall Thickness ≤ 0.500 in. (12.7 mm)							
<2.375	<60.3	0	2	2	0	0	4 ^a
2.375 to 4.500	60.3 to 114.3	0	2	2	0	0	4
>4.500 to 12.750	>114.3 to 323.9	2	2	2	0	0	6
>12.750	>323.9	4	4	2	2	0	12
Wall Thickness > 0.500 in. (12.7 mm)							
≤4.500	≤114.3	0	2	0	0	2	4
>4.500 to 12.750	>114.3 to 323.9	2	2	0	0	2	6
>12.750	>323.9	4	4	0	0	4	12

^a For pipe less than or equal to 1.315 in. (33.4 mm) in outside diameter, nick break and root bead specimens from two welds or one full-section tensile strength specimen is taken.

6.5.6 Sampling of Test Fillet Welds

To test fillet welds, specimens shall be cut from each test weld. Figure 10 shows the locations from which the specimens are to be removed if the test weld is a complete circumferential weld. If the test weld consists of segments of pipe nipples, an approximately equal number of specimens shall be removed from each segment. The specimens shall be air cooled to ambient temperature prior to testing.

6.5.7 Test Method and Requirements for Fillet Welds

The fillet weld specimens shall be prepared and the test shall be performed as described in 5.8.

6.6 Nondestructive Testing (NDT)—Butt Welds Only

6.6.1 General

At the company's option, the qualification butt weld may be examined by radiography or automatic ultrasonic testing using a qualified NDT procedure in lieu of the tests specified in 6.5.

6.6.2 Inspection Requirements

When radiography is utilized, radiographs shall be made of each of the test welds. The welder shall be disqualified if any of the test welds do not meet the requirements of 9.3.

When automatic ultrasonic testing is utilized, each test weld shall be fully examined. The welder shall be disqualified if any of the test welds do not meet the requirements of 9.6.

Radiographic testing or automatic ultrasonic testing shall not be used for the purpose of locating sound areas or areas that contain imperfections and subsequently making tests of such areas to qualify or disqualify a welder.

6.7 Retesting

If, in the mutual opinion of the company and the contractor's representatives, a welder fails to pass the qualification test because of unavoidable conditions or conditions beyond the welder's control, the welder may be given a second opportunity to qualify. No further retests shall be given until the welder has submitted proof of subsequent welder training that is acceptable to the company.

6.8 Records

A record shall be maintained of the tests given to each welder and of the detailed results of each test. A form similar to that shown in Figure 2 should be used. (This form should be developed to suit the needs of the individual company but must be sufficiently detailed to demonstrate that the qualification test met the requirements of this standard.) A list of qualified welders and the procedures for which they are qualified shall be maintained. A welder may be required to requalify if a question arises about the welder's competence.

7 Design and Preparation of a Joint for Production Welding

7.1 General

Piping shall be welded by qualified welders using qualified procedures. The surfaces to be welded shall be smooth, uniform, and free from laminations, tears, scale, slag, grease, paint, and other deleterious material that might adversely affect the welding. The joint design and spacing between abutting ends shall be in accordance with the welding procedure specification used.

7.2 Alignment

The alignment of abutting ends shall minimize the offset between surfaces. For pipe ends of the same specified thickness, the offset should not exceed $\frac{1}{8}$ in. (3 mm). Larger variations are permissible provided the variation is caused by variations of the pipe end dimensions within the pipe purchase specification tolerances, and such variations have been distributed essentially uniformly around the circumference of the pipe. Hammering of the pipe to obtain proper lineup should be kept to a minimum.

7.3 Use of Lineup Clamp for Butt Welds

Lineup clamps shall be used for butt welds in accordance with the welding procedure specification. When it is permissible to remove the lineup clamp before the root bead is completed, the completed part of the bead shall be in approximately equal segments spaced approximately equally around the circumference of the joint. However, when an internal lineup clamp is used and conditions make it difficult to prevent movement of the pipe or if the weld will be unduly stressed, the root bead shall be completed before clamp tension is released. Root bead segments used in connection with external clamps should be uniformly spaced around the circumference of the pipe and shall have an aggregate length of at least 50 % of the pipe circumference before the clamp is removed.

7.4 Bevel

7.4.1 Mill Bevel

All mill bevels on pipe ends shall conform to the joint design used in the welding procedure specification.

7.4.2 Field Bevel

Pipe ends should be field beveled by machine tool or machine oxygen cutting. If authorized by the company, manual oxygen cutting may also be used. The beveled ends shall be reasonably smooth and uniform, and dimensions shall be in accordance with the welding procedure specification.

7.5 Weather Conditions

Welding shall not be done when the quality of the completed weld would be impaired by the prevailing weather conditions, including but not limited to airborne moisture, blowing sands, or high winds. Windshields may be used when practical. The company shall decide if weather conditions are suitable for welding.

7.6 Clearance

When the pipe is welded above ground, the working clearance around the pipe at the weld should not be less than 16 in. (400 mm). When the pipe is welded in a trench, the bell hole shall be large enough to provide the welder or welders with ready access to the joint.

7.7 Cleaning Between Beads

Scale and slag shall be removed from each bead and groove. Power tools shall be used when called for in the welding procedure specification; otherwise, cleaning may be performed with either hand or power tools.

When semiautomatic or mechanized welding is used, surface porosity clusters, bead starts, and high points shall be removed by grinding before weld metal is deposited over them. When requested by the company, heavy glass deposits shall be removed before weld metal is deposited over them.

7.8 Position Welding

7.8.1 Procedure

All position welds shall be made with the parts to be joined secured against movement and with adequate clearance around the joint to allow the welder or welders space in which to work.

7.8.2 Filler and Finish Beads

For position welding, the number of filler and finish beads shall allow the completed weld a substantially uniform cross section around the entire circumference of the pipe. At no point shall the crown surface fall below the outside surface of the pipe, nor should it be raised above the parent metal by more than $\frac{1}{16}$ in. (1.6 mm).

Two beads shall not be started at the same location. The face of the completed weld should be approximately $\frac{1}{8}$ in. (3 mm) wider than the width of the original groove. The completed weld shall be thoroughly brushed and cleaned.

7.9 Roll Welding

7.9.1 Alignment

At the company's option, roll welding shall be permitted, provided alignment is maintained by the use of skids or a structural framework with an adequate number of roller dollies to prevent sag in the supported lengths of pipe.

7.9.2 Filler and Finish Beads

For roll welding, the number of filler and finish beads shall be such that the completed weld has a substantially uniform cross section around the entire circumference of the pipe. At no point shall the crown surface fall below the outside surface of the pipe, nor should it be raised above the parent metal by more than $\frac{1}{16}$ in. (1.6 mm).

The face of the completed weld should be approximately $\frac{1}{8}$ in. (3 mm) wider than the width of the original groove. As the welding progresses, the pipe shall be rolled to maintain welding at or near the top of the pipe. The completed weld shall be thoroughly brushed and cleaned.

7.10 Identification of Welds

Each welder shall identify the welder's work in the manner prescribed by the company.

7.11 Preheat and PWHT

Preheat and PWHT practices as listed on the qualified welding procedure specification shall be followed when materials or whether conditions make either or both treatments necessary.

8 Inspection and Testing of Production Welds

8.1 Rights of Inspection

The company shall have the right to inspect all welds by nondestructive means or by removing welds and subjecting them to mechanical tests. The inspection may be made during the welding or after the weld has been completed. The frequency of inspection shall be as specified by the company.

8.2 Methods of Inspection

NDT may consist of radiographic testing or another method specified by the company. The method used shall produce indications of imperfections that can be accurately interpreted and evaluated. The welds shall be evaluated

on the basis of either Section 9 or, at the company's option, Annex A. In the latter case, more extensive inspection to determine the imperfection size is required.

Destructive testing shall consist of the removal of completed welds, sectioning of the welds into specimens, and the examination of the specimens. The specimens shall be prepared in accordance with and shall meet the requirements of 6.5. The company shall have the right to accept or reject any weld that does not meet the requirements for the method by which it was inspected. The welder who makes a weld that fails to comply with the requirements may be disqualified from further work.

Operators of nondestructive inspection equipment may be required to demonstrate the inspection procedure's capability to detect defects and the operator's ability to properly interpret the indications given by the equipment.

Trepanning methods of testing shall not be used.

8.3 Qualification of Inspection Personnel

Welding inspection personnel shall be qualified by experience and training for the specified inspection task they perform. Their qualifications shall be acceptable to the company.

Documentation of these qualifications shall be retained by the company and shall include but is not limited to the following:

- a) education and experience,
- b) training,
- c) results of any qualification examinations.

8.4 Certification of NDT Personnel

8.4.1 Procedures

NDT personnel shall be certified to Level I, II, or III in accordance with the recommendations of ASNT SNT-TC-1A, ASNT ACCP, or any other recognized national certification program that shall be acceptable to the company for the test method used. Only Level II or III personnel shall interpret test results.

8.4.2 Record

A record of certified NDT personnel shall be maintained by the company. The record shall include the results of certification tests, the agency and person granting certification, and the date of certification. NDT personnel may be required to be recertified at the company's option or if any question arises about their ability. All levels of NDT personnel shall be recertified at least every five years.

8.4.3 Vision Examinations

8.4.3.1 Near Distance

All NDT personnel shall be examined to ensure that they have natural or corrected near-distance acuity in at least one eye such that each individual is capable of reading Jaeger Number 1 test chart or equivalent at a distance of not less than 12 in.

8.4.3.2 Color Vision

NDT personnel for all methods shall demonstrate the ability to differentiate among the colors used in the method.

8.4.3.3 Frequency

Near vision examinations shall be administered at least annually. Color differentiation examinations shall be repeated at least every five years.

9 Acceptance Standards for NDT

9.1 General

The acceptance standards presented in this section apply to imperfections located by radiographic, magnetic particle, liquid penetrant, and ultrasonic test methods. They may also be applied to visual inspection. NDT shall not be used to select welds that are subjected to destructive testing in accordance with 6.5.

9.2 Rights of Rejection

All nondestructive test methods are limited in the information that can be derived from the indications they produce. The company may therefore reject any weld that appears to meet these acceptance standards if, in its opinion, the depth of an imperfection may be detrimental to the weld.

9.3 Radiographic Testing

NOTE All densities referred to in 9.3.1 through 9.3.13 are based on negative images.

9.3.1 Inadequate Penetration Without High-low (IP)

IP is defined as the incomplete filling of the weld root. This condition is shown schematically in Figure 13. IP shall be considered a defect should any of the following conditions exist:

- the length of an individual indication of IP exceeds 1 in. (25 mm),
- the aggregate length of indications of IP in any continuous 12 in. (300 mm) length of weld exceeds 1 in. (25 mm),
- the aggregate length of indications of IP exceeds 8 % of the weld length in any weld less than 12 in. (300 mm) in length.

NOTE One or both root faces may be inadequately filled at the inside surface.

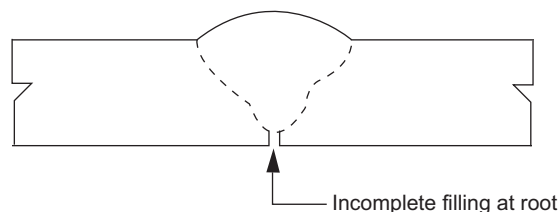

Figure 13—Inadequate Penetration Without High-low

9.3.2 Inadequate Penetration Due to High-low (IPD)

IPD is defined as the condition that exists when one edge of the root is exposed (or unbonded) because adjacent pipe or fitting joints are misaligned. This condition is shown schematically in Figure 14. IPD shall be considered a defect should any of the following conditions exist:

- the length of an individual indication of IPD exceeds 2 in. (50 mm),
- the aggregate length of indications of IPD in any continuous 12 in. (300 mm) length of weld exceeds 3 in. (75 mm).

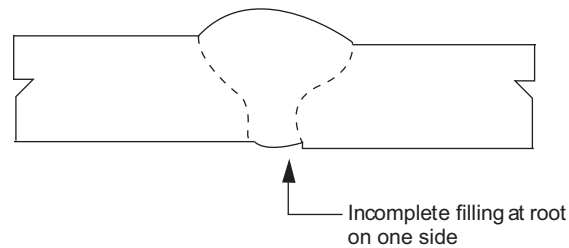

Figure 14—Inadequate Penetration Due to High-low

9.3.3 Inadequate Cross Penetration (ICP)

ICP is defined as a subsurface imperfection between the first inside pass and the first outside pass that is caused by inadequately penetrating the vertical land faces. This condition is shown schematically in Figure 15. ICP shall be considered a defect should any of the following conditions exist:

- the length of an individual indication of ICP exceeds 2 in. (50 mm),
- the aggregate length of indications of ICP in any continuous 12 in. (300 mm) length of weld exceeds 2 in. (50 mm).

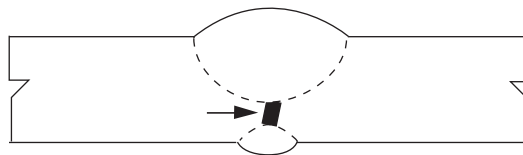

Figure 15—Inadequate Cross Penetration

9.3.4 Incomplete Fusion (IF)

IF is defined as a surface imperfection between the weld metal and the base material that is open to the surface. This condition is shown schematically in Figure 16. IF shall be considered a defect should any of the following conditions exist:

- the length of an individual indication of IF exceeds 1 in. (25 mm),
- the aggregate length of indications of IF in any continuous 12 in. (300 mm) length of weld exceeds 1 in. (25 mm),
- the aggregate length of indications of IF exceeds 8 % of the weld length in any weld less than 12 in. (300 mm) in length.

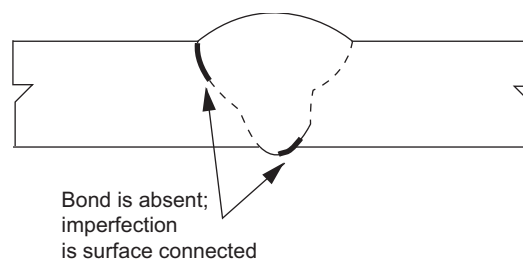

Figure 16—Incomplete Fusion at Root of Bead or Top of Joint

9.3.5 Incomplete Fusion Due to Cold Lap (IFD)

IFD is defined as an imperfection between two adjacent weld beads or between the weld metal and the base metal that is not open to the surface. This condition is shown schematically in Figure 17. IFD shall be considered a defect should any of the following conditions exist:

- the length of an individual indication of IFD exceeds 2 in. (50 mm),
- the aggregate length of indications of IFD in any continuous 12 in. (300 mm) length of weld exceeds 2 in. (50 mm),
- the aggregate length of indications of IFD exceeds 8 % of the weld length.

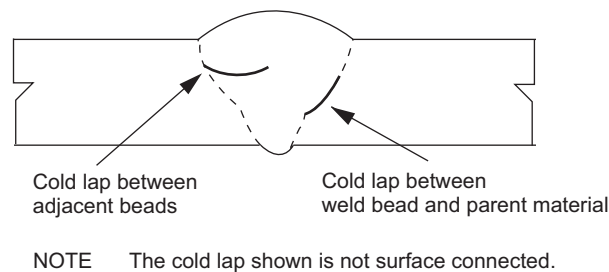

Figure 17—Incomplete Fusion Due to Cold Lap

9.3.6 Internal Concavity (IC)

IC is defined in 3.1.13 and is shown schematically in Figure 18. Any length of IC is acceptable, provided the density of the radiographic image of the IC does not exceed that of the thinnest adjacent parent material. For areas that exceed the density of the thinnest adjacent parent material, the criteria for BT (see 9.3.7) are applicable.

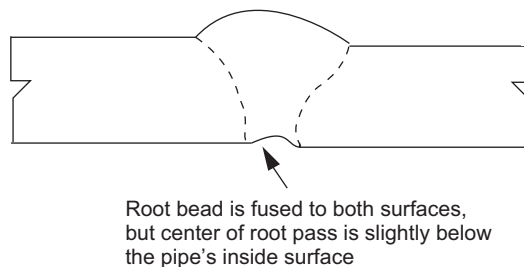

Figure 18—Internal Concavity

9.3.7 Burn-through (BT)

9.3.7.1 General

A BT is defined as a portion of the root bead where excessive penetration has caused the weld puddle to be blown into the pipe.

9.3.7.2 Large Diameter Pipe

For pipe with a specified OD greater than or equal to 2.375 in. (60.3 mm), a BT shall be considered a defect should any of the following conditions exist:

- a) the maximum dimension exceeds $\frac{1}{4}$ in. (6 mm) and the density in any portion of the BT's image exceeds that of the thinnest adjacent parent material;
- b) the maximum dimension exceeds the thinner of the specified wall thicknesses joined and the density in any portion of the BT's image exceeds that of the thinnest adjacent parent material;
- c) the sum of the maximum dimensions of separate BTs whose image density for any portion of the BTs exceeds that of the thinnest adjacent parent material and exceeds $\frac{1}{2}$ in. (13 mm) in any continuous 12 in. (300 mm) length of weld or the total weld length, whichever is less.

9.3.7.3 Small Diameter Pipe

For pipe with a specified OD less than 2.375 in. (60.3 mm), a BT shall be considered a defect when any of the following conditions exists:

- a) the maximum dimension exceeds $\frac{1}{4}$ in. (6 mm) and the density in any portion of the BT's image exceeds that of the thinnest adjacent parent material;
- b) the maximum dimension exceeds the thinner of the specified wall thicknesses joined and the density in any portion of the BT's image exceeds that of the thinnest adjacent parent material;
- c) more than one BT of any size is present and the density in any portion of the BT's image exceeds that of the thinnest adjacent parent material.

9.3.8 Slag Inclusions

9.3.8.1 General

A slag inclusion is defined as a nonmetallic solid entrapped in the weld metal or between the weld metal and the parent material. Elongated slag inclusions (ESIs)—for example, continuous or broken slag lines or wagon tracks—are usually found at the fusion zone. Isolated slag inclusions (ISIs) are irregularly shaped and may be located anywhere in the weld. For evaluation purposes, when the size of a radiographic indication of slag is measured, the indication's maximum dimension shall be considered its length.

9.3.8.2 Large Diameter Pipe

For pipe with a specified OD greater than or equal to 2.375 in. (60.3 mm), slag inclusions shall be considered a defect should any of the following conditions exist:

- a) the length of an ESI indication exceeds 2 in. (50 mm),

NOTE Parallel ESI indications separated by approximately the width of the root bead (wagon tracks) shall be considered a single indication unless the width of either of them exceeds $\frac{1}{32}$ in. (0.8 mm). In that event, they shall be considered separate indications.

- b) the aggregate length of ESI indications in any continuous 12 in. (300 mm) length of weld exceeds 2 in. (50 mm),
- c) the width of an ESI indication exceeds $\frac{1}{16}$ in. (1.6 mm),
- d) the aggregate length of ISI indications in any continuous 12 in. (300 mm) length of weld exceeds $\frac{1}{2}$ in. (13 mm),

- e) the width of an ISI indication exceeds $\frac{1}{8}$ in. (3 mm),
- f) more than four ISI indications with the maximum width of $\frac{1}{8}$ in. (3 mm) are present in any continuous 12 in. (300 mm) length of weld,
- g) the aggregate length of ESI and ISI indications exceeds 8 % of the weld length.

9.3.8.3 Small Diameter Pipe

For pipe with a specified OD less than 2.375 in. (60.3 mm), slag inclusions shall be considered a defect should any of the following conditions exist:

- a) the length of an ESI indication exceeds three times the thinner of the specified wall thicknesses joined,

NOTE Parallel ESI indications separated by approximately the width of the root bead (wagon tracks) shall be considered a single indication unless the width of either of them exceeds $\frac{1}{32}$ in. (0.8 mm). In that event, they shall be considered separate indications.

- b) the width of an ESI indication exceeds $\frac{1}{16}$ in. (1.6 mm),
- c) the aggregate length of ISI indications exceeds two times the thinner of the specified wall thicknesses joined and the width exceeds one-half the thinner of the specified wall thicknesses joined,
- d) the aggregate length of ESI and ISI indications exceeds 8 % of the weld length.

9.3.9 Porosity

9.3.9.1 General

Porosity is defined as gas trapped by solidifying weld metal before the gas has a chance to rise to the surface of the molten puddle and escape. Porosity is generally spherical but may be elongated or irregular in shape, such as piping (wormhole) porosity. When the size of the radiographic indication produced by a pore is measured, the maximum dimension of the indication shall apply to the criteria given in 9.3.9.2 through 9.3.9.4.

9.3.9.2 Individual or Scattered Porosity

Individual or scattered porosity shall be considered a defect should any of the following conditions exist:

- a) the size of an individual pore exceeds $\frac{1}{8}$ in. (3 mm) in diameter or 25 % of the specified wall thickness, whichever is less;
- b) the size of an individual pore exceeds 25 % of the thinner of the specified wall thicknesses joined, but no more than $\frac{1}{8}$ in. (3 mm) in diameter;
- c) the distribution of scattered porosity exceeds the concentration permitted by Figure 19 or Figure 20.

9.3.9.3 Cluster Porosity (CP)

CP that occurs in any pass except the finish pass shall comply with the criteria of 9.3.9.2. CP that occurs in the finish pass shall be considered a defect should any of the following conditions exist:

- a) the diameter of the cluster exceeds $\frac{1}{2}$ in. (13 mm);
- b) the aggregate length of CP in any continuous 12 in. (300 mm) length of weld exceeds $\frac{1}{2}$ in. (13 mm).

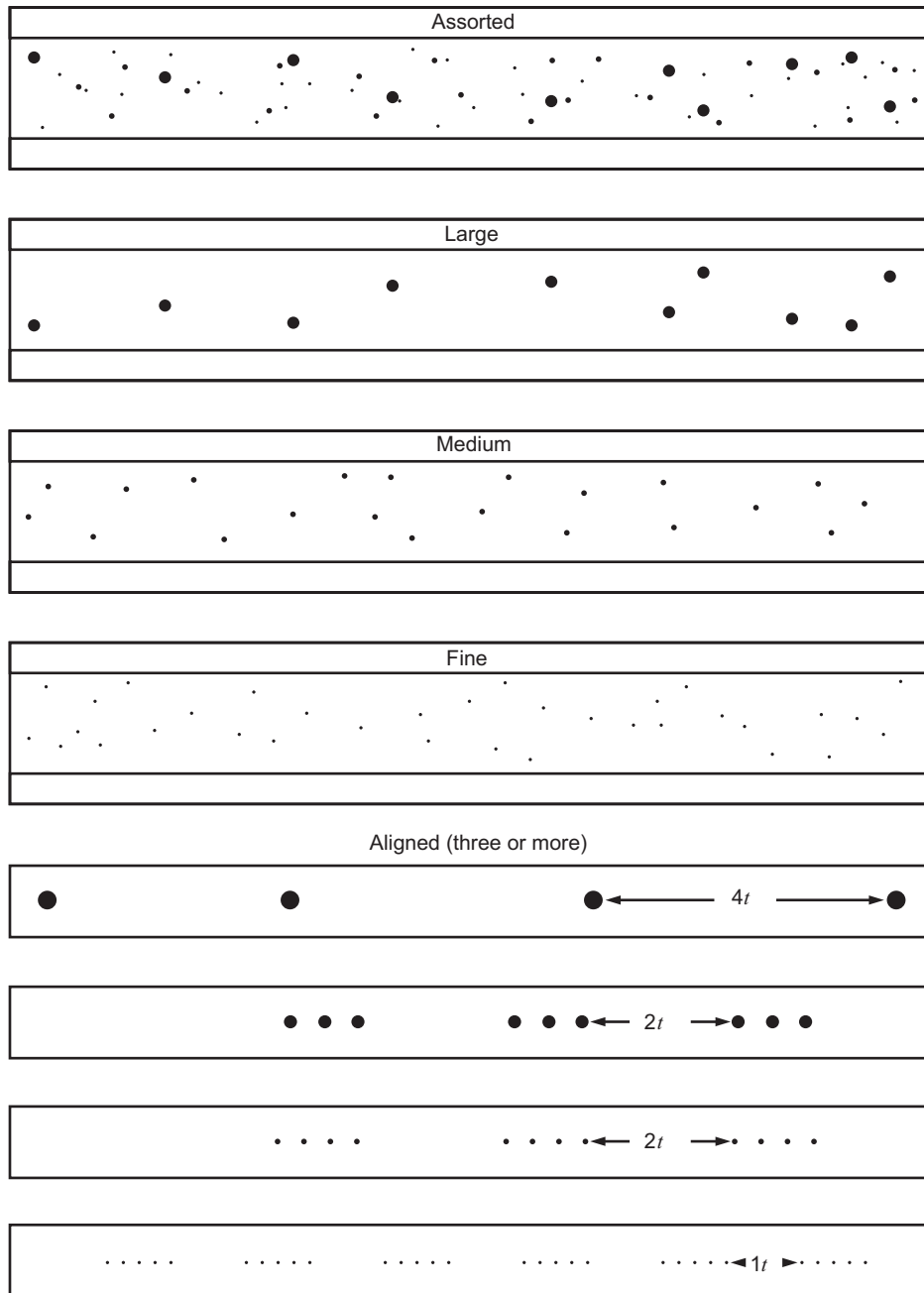

Figure 19—Maximum Distribution of Gas Pockets: Wall Thickness (t) Less Than or Equal to 0.500 in. (12.7 mm)

9.3.9.4 Hollow Bead (HB) Porosity

Hollow bead porosity is defined as elongated linear porosity that occurs in the root pass. HB shall be considered a defect should any of the following conditions exist:

- a) the length of an individual indication of HB exceeds $\frac{1}{2}$ in. (13 mm);
- b) the aggregate length of indications of HB in any continuous 12 in. (300 mm) length of weld exceeds 2 in. (50 mm);

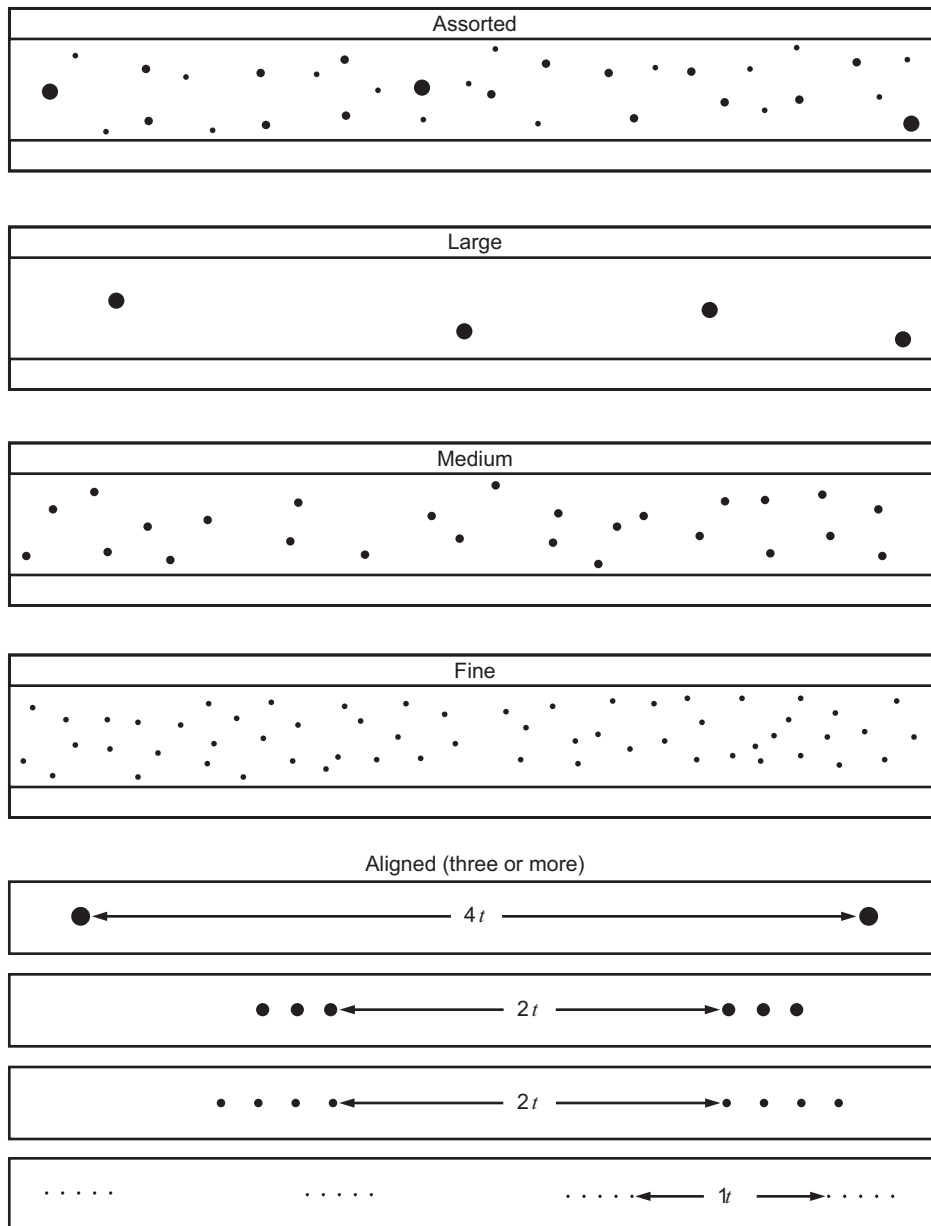

Figure 20—Maximum Distribution of Gas Pockets: Wall Thickness (t) Greater Than 0.500 in. (12.7 mm)

- c) individual indications of HB, each greater than $\frac{1}{4}$ in. (6 mm) in length, are separated by less than 2 in. (50 mm);
- d) the aggregate length of all indications of HB exceeds 8 % of the weld length.

9.3.10 Cracks

Cracks shall be considered a defect should any of the following conditions exists:

- a) the crack, of any size or location in the weld, is not a shallow crater crack or star crack;
- b) the crack is a shallow crater crack or star crack with a length that exceeds $\frac{5}{32}$ in. (4 mm).

NOTE Shallow crater cracks or star cracks are located at the stopping point of weld beads and are the result of weld metal contractions during solidification.

9.3.11 Undercutting

Undercutting is defined as a groove melted into the parent material adjacent to the toe or root of the weld and left unfilled by weld metal. Undercutting adjacent to the cover pass (EU) or undercutting adjacent to root pass (IU) shall be considered a defect should any of the following conditions exist:

- a) the aggregate length of indications of EU and IU, in any combination, in any continuous 12 in. (300 mm) length of weld exceeds 2 in. (50 mm);
- b) the aggregate length of indications of EU and IU, in any combination, exceeds one-sixth of the weld length.

NOTE See 9.7 for acceptance standards for undercutting when visual and mechanical measurements are employed.

9.3.12 Accumulation of Imperfections

Excluding incomplete penetration due to high-low and undercutting, any accumulation of imperfections shall be considered a defect should any of the following conditions exist:

- a) the aggregate length of indications in any continuous 12 in. (300 mm) length of weld exceeds 2 in. (50 mm),
- b) the aggregate length of indications exceeds 8 % of the weld length.

9.3.13 Base Material Imperfections

Imperfections in the base material detected by radiographic testing shall be reported to the company. The disposition of these imperfections shall be as directed by the company.

9.4 Magnetic Particle Testing

9.4.1 Classification of Indications

Indications produced by magnetic particle testing are not necessarily imperfections. Magnetic and metallurgical variations may produce indications that are similar to those produced by imperfections but that are not relevant to acceptability. The following criteria apply when indications are evaluated.

- a) Any indication with a maximum dimension of $1/16$ in. (1.6 mm) or less shall be classified as nonrelevant. Any larger indication believed to be nonrelevant shall be regarded as relevant until reexamined by magnetic particle or another NDT method to determine whether or not an actual imperfection exists. The surface may be ground or otherwise conditioned before reexamination. After an indication is determined to be nonrelevant, other nonrelevant indications of the same type need not be reexamined.
- b) Relevant indications are those caused by imperfections. Linear indications are those in which the length is more than three times the width. Rounded indications are those in which the length is three times the width or less.

9.4.2 Acceptance Standards

Relevant indications shall be considered defects should any of the following conditions exist:

- a) linear indications evaluated as crater cracks or star cracks exceed $5/32$ in. (4 mm) in length,
- b) linear indications are evaluated as cracks other than crater cracks or star cracks,

- c) linear indications are evaluated as IF and exceed 1 in. (25 mm) in total length in a continuous 12 in. (300 mm) length of weld or 8 % of the weld length.

Rounded indications shall be evaluated according to the criteria of 9.3.9.2 and 9.3.9.3, as applicable. For evaluation purposes, the maximum dimension of a rounded indication shall be considered its size.

NOTE When doubt exists about the type of imperfection being disclosed by an indication, verification may be obtained by using other NDT methods.

9.4.3 Base Material Imperfections

Imperfections in base material detected by magnetic particle testing shall be reported to the company. The disposition of these imperfections shall be as directed by the company.

9.5 Liquid Penetrant Testing

9.5.1 Classification of Indications

Indications produced by liquid penetrant testing are not necessarily imperfections. Machining marks, scratches, and surface conditions may produce indications that are similar to those produced by imperfections but that are not relevant to acceptability. The following criteria shall apply when indications are evaluated.

- a) Any indication with a maximum dimension of $1/16$ in. (2 mm) or less shall be classified as nonrelevant. Any larger indication believed to be nonrelevant shall be regarded as relevant until reexamined by liquid penetrant or another NDT method to determine whether or not an actual imperfection exists. The surface may be ground or otherwise conditioned before reexamination. After an indication is determined to be nonrelevant, other nonrelevant indications of the same type need not be reexamined.
- b) Relevant indications are those caused by imperfections. Linear indications are those in which the length is more than three times the width. Rounded indications are those in which the length is three times the width or less.

9.5.2 Acceptance Standards

Relevant indications shall be considered defects should any of the following conditions exist:

- a) linear indications are evaluated as crater cracks or star cracks and exceed $5/32$ in. (4 mm) in length,
- b) linear indications are evaluated as cracks other than crater cracks or star cracks,
- c) linear indications are evaluated as IF and exceed 1 in. (25 mm) in total length in a continuous 12 in. (300 mm) length of weld or 8 % of the weld length.

Rounded indications shall be evaluated according to the criteria of 9.3.9.2 and 9.3.9.3, as applicable. For evaluation purposes, the maximum dimension of a rounded indication shall be considered its size.

NOTE When doubt exists about the type of imperfection being disclosed by an indication, verification may be obtained by using other NDT methods.

9.5.3 Base Material Imperfections

Imperfections in the base material detected by liquid penetrant testing shall be reported to the company. The disposition of these imperfections shall be as directed by the company.

9.6 Ultrasonic Testing

9.6.1 Classification of Indications

9.6.1.1 General

Indications produced by ultrasonic testing are not necessarily defects. Changes in the weld geometry due to alignment offset of abutting pipe ends, changes in weld reinforcement profile of ID root and OD capping passes, internal chamfering, and ultrasonic wave mode conversion due to such conditions may cause geometric indications that are similar to those caused by weld imperfections but that are not relevant to acceptability.

9.6.1.2 Linear Indications

Linear indications are defined as indications with their greatest dimension in the weld length direction. Typical linear indications may be caused by, but are not limited to, the following types of imperfections: IP, IPD, ICP, IF, IFD, ESI, cracks, EU, IU, and HB.

9.6.1.3 Transverse Indications

Transverse indications are defined as indications with their greatest dimension across the weld. Typical transverse indications may be caused by, but are not limited, to the following types of imperfections: cracks, ISIs, and IFD at start/stops in the weld passes.

9.6.1.4 Volumetric Indications

Volumetric indications are defined as three-dimensional indications. Such indications may be caused by single or multiple inclusions, voids, or pores. Partially filled voids, pores, or small inclusions at start/stops in weld passes may cause larger indications in the transverse direction than in the weld length direction. Typical volumetric indications may be caused by, but are not limited to, the following types of imperfections: IC, BT, ISIs, porosity, and CP.

9.6.1.5 Relevant Indications

Relevant indications are those caused by imperfections. Relevant indications shall be evaluated at the evaluation level given in 11.4.7 to the acceptance standards given in 9.6.2.

NOTE When doubt exists about the type of imperfection being disclosed by an indication, verification may be obtained by using other NDT methods.

9.6.2 Acceptance Standards

9.6.2.1 General

Indications shall be considered defects should any of the following conditions exist:

- a) indications determined to be cracks,
- b) individual indications with a vertical height (through-wall) dimension determined to be greater than one quarter of the wall thickness,
- c) multiple indications at the same circumferential location with a summed vertical height (through-wall) dimension exceeding one quarter the wall thickness.

9.6.2.2 Linear Surface (LS) Indications

LS indications (other than cracks) interpreted to be open to the ID or OD surface shall be considered defects should any of the following conditions exist:

- a) the aggregate length of LS indications in any continuous 12 in. (300 mm) length of weld exceeds 1 in. (25 mm),
- b) the aggregate length of LS Indications exceeds 8 % of the weld length.

9.6.2.3 Linear Buried (LB) Indications

LB indications (other than cracks) interpreted to be subsurface within the weld and not ID or OD surface connected shall be considered defects should any of the following conditions exist:

- a) the aggregate length of LB indications in any continuous 12 in. (300 mm) length of weld exceeds 2 in. (50 mm),
- b) the aggregate length of LB indications exceeds 8 % of the weld length.

9.6.2.4 Transverse (T) Indications

T indications (other than cracks) shall be considered volumetric and evaluated using the criteria for volumetric indications. The letter T shall be used to designate all reported transverse indications.

9.6.2.5 Volumetric Cluster (VC) Indications

VC indications shall be considered defects when the maximum dimension of VC indications exceeds $\frac{1}{2}$ in. (13 mm).

9.6.2.6 Volumetric Individual (VI) Indications

VI indications shall be considered defects when the maximum dimension of VI indications exceeds $\frac{1}{8}$ in. (3 mm).

9.6.2.7 Volumetric Root (VR) Indications

VR indications interpreted to be open to the ID surface shall be considered defects should any of the following conditions exist:

- a) the maximum dimension of VR indications exceeds $\frac{1}{4}$ in. (6 mm) or the specified wall thickness, whichever is less;
- b) the total length of VR indications exceeds $\frac{1}{2}$ in. (13 mm) in any continuous 12 in. (300 mm) length.

9.6.2.8 Accumulation

Any accumulation of relevant indications shall be considered a defect when any of the following conditions exist:

- a) the aggregate length of indications above evaluation level exceeds 2 in. (50 mm) in any 12 in. (300 mm) length of weld,
- b) the aggregate length of indications above evaluation level exceeds 8 % of the weld length.

9.6.3 Base Material Imperfections

Imperfections in the base material detected by ultrasonic testing shall be reported to the company. The disposition of these imperfections shall be as directed by the company.

9.7 Visual Acceptance Standards for Undercutting

9.7.1 General

Undercutting is defined in 9.3.11. The acceptance standards in 9.7.2 supplement but do not replace visual inspection requirements found elsewhere in this standard.

9.7.2 Acceptance Standards

When visual and mechanical means are used to determine depth, undercutting adjacent to the cover or root bead shall not exceed the dimensions given in Table 4. When both mechanical and radiographic measurements are available, the mechanical measurements shall govern.

Table 4—Maximum Dimensions of Undercutting

Depth	Length
>1/32 in. (0.8 mm) or >12.5 % of pipe wall thickness, whichever is smaller	Not acceptable
>1/64 in. (0.4 mm) but ≤ 1/32 in. (0.8 mm) or >6 % but ≤ 12.5 % of pipe wall thickness, whichever is smaller	2 in. (50 mm) in a continuous 12 in. (300 mm) weld length or one-sixth the weld length, whichever is smaller
≤1/64 in. (0.4 mm) or ≤ 6 % of pipe wall thickness, whichever is smaller	Acceptable, regardless of length

10 Repair and Removal of Weld Defects

10.1 General

Weld defects may be identified during visual or nondestructive testing, or during the company's review of nondestructive testing results.

10.2 Authorization for Repair

10.2.1 Company Authorization

Company authorization is required for crack repairs, back weld repairs, and double repairs and as otherwise noted in 10.2. Company authorization is not required for any repairs that do not involve the application of heat or weld metal, such as grinding, filing, etc.

10.2.2 Crack Repairs

Cracked welds shall be cut out unless permitted by 9.3.10 or repair is authorized by the company. When a crack repair is authorized:

- a) a cracked butt weld or branch weld may be repaired by complete or partial removal of the weld provided the length of a single crack or aggregate length of more than one crack in a single repair area is less than 8 % of the weld length using a qualified repair procedure;
- b) a cracked fillet weld may be repaired by complete or partial removal of the fillet weld using a qualified repair procedure;
- c) a butt weld or branch weld that contains multiple repair areas with crack(s) may not be repaired unless the total accumulated repair length is less than 8 % of the weld length and a qualified repair procedure is used;
- d) a double repair of a crack is not permitted. Additional cracking in any weld after repair shall require a cut out;

- e) shallow crater cracks or star cracks found and contained completely in internal or external weld reinforcement may be repaired by grinding (i.e. abrasive methods) without a qualified repair procedure. If the grinding exceeds the internal or external reinforcement, the reinforcement shall be replaced using a qualified weld procedure.

10.2.3 Repairs of Defects Other Than Cracks

Defects other than cracks in the root, filler, and finish beads may be repaired with prior company authorization. A qualified repair procedure shall be required whenever a repair is made by welding when:

- a) using a welding process, combination of welding processes, or method of application or filler metals different from that used to make the original weld; or
- b) repairs are made in a previously welded repaired area; or
- c) required by the company.

10.2.4 Grinding Repairs

Grinding repairs may be used to remove defects in the reinforcement of root beads and cover passes provided:

- there is a smooth transition free of undercutting and other imperfections between the ground area and the original weld, and
- pipe surface contour and the minimum wall and weld thickness requirements are not violated.

If the minimum wall/weld thickness is not known, the grinding depth is limited to the excess root bead penetration or external reinforcement. The grinding repair length and number of grinding repair areas is not limited. Grinding repairs do not require use of a qualified repair procedure.

10.2.5 Back Weld Repairs

When back weld repairs are permitted by the company, a repair procedure shall be qualified in accordance with 10.3.

10.2.6 Welded Double Repairs

A double repair requires prior company authorization. For repair procedure qualification purposes, this is a partial thickness or full thickness repair that tests a HAZ that has received three full thermal cycles from welding. A grinding repair is not considered to be one of the thermal cycles.

NOTE Subsequent repair of a double repair weld is not permitted unless specifically authorized by the company and repaired with a qualified repair procedure appropriate for the number of thermal cycles used. A qualified repair procedure for a double repair may be used for a single repair with prior company authorization.

10.2.7 Repair Area Length

10.2.7.1 Large Diameter Pipe

For pipe with a specified OD greater than or equal to 2.375 in. (60.3 mm), the length of an individual repair area or total length of accumulated repair areas within a completed weld for a partial thickness or full thickness repair shall not exceed a percentage of weld length determined by the company.

The length of an individual repair area or total length of accumulated repair areas determined by the company should be based on sound welding practice and/or engineering analysis of the installation stresses (i.e. combined axial and bending) and repair sequence for segmented repairs.

10.2.7.2 Small Diameter Pipe

For pipe with a specified OD less than 2.375 in. (60.3 mm), all repairs require company authorization.

10.2.7.3 Limit Increases

An increase in the specified individual or accumulated repair area length limits are subject to the discretion of the company.

10.2.8 Minimum Deposited Repair Weld Length

All repair welds shall have an individual deposited repair weld length of at least 2 in. (50 mm) or as otherwise specified by the company.

10.3 Repair Procedure

10.3.1 General

When a repair procedure is required, the procedure shall be established and qualified to demonstrate that a repair weld with suitable mechanical properties and soundness can be produced. The repair weld shall meet the minimum requirements of the production weld or as otherwise specified by the company.

10.3.2 Types of Repair Procedures

Types of repair procedures may include, but are not limited to, the following:

- a) full thickness repair,
- b) internal partial thickness repair,
- c) external partial thickness repair,
- d) cover pass repair,
- e) back weld repair.

10.3.3 Qualification

Repair procedures shall be qualified by visual and destructive testing. NDT may be required at the discretion of the company. For repair procedure qualification, sample preparation and destructive and nondestructive testing shall not commence until the repair weld has been allowed to cool to ambient temperature.

The minimum total number of specimens and the types of destructive tests to which each repair procedure shall be submitted are shown in Table 5. At the discretion of the company, additional types and number of tests may be required. When the production welding procedure was qualified with Charpy impact testing, Charpy impact testing shall also be performed to qualify partial thickness and full thickness repair procedures. As noted in Table 5, when wall thickness is over 0.500 in. (12.7 mm), the side bend tests shall be substituted for face bend or root bend tests.

NOTE Dependent on pipe material or welding process, the company may require additional cooling time prior to destructive and nondestructive testing.

Table 5—Type and Number of Butt Weld Test Specimens per Repair Type for Repair Procedure Qualification

Repair Type	Tensile Strength	Nick Break	Root Bend	Face Bend	Side Bend	Macro/Hardness ^b	Total (Minimum)	Charpy Impact
Full thickness	1	1	1 ^a	1 ^a	0	1	5	Note c
Internal partial thickness	1	1	1 ^a	0	0	1	4	Note c
External partial thickness	1	1	0	1 ^a	0	1	4	Note c
Cover pass	0	0	0	1 ^a	0	1	2	0
Back weld	0	1	1 ^a	0	0	1	3	0

^a Side bend tests are substituted for face bend or root bend tests when wall thickness is over 0.500 in. (12.7 mm).

^b The hardness survey is made on the macrosection test specimen.

^c When required by the company.

10.3.4 Specification Information

A repair procedure, as a minimum, shall include the following.

- a) Location and method for exploration of the defect(s)—identify excavation location at either weld centerline and/or fusion line.
- b) Method of defect removal—including method of inspection by which the repair groove shall be examined to confirm complete removal of the defect.
- c) Requirements for preheat and interpass temperature—temperature (minimum/maximum), method of application, location, and extent shall be included.
- d) Welding processes and other specification information contained in 5.3.2.
- e) Requirement, if any, for interpass NDT.
- f) Methods (i.e. storage, handling, usage) to control filler metals, fluxes, and shielding gases when hydrogen control is required per the manufacturer's recommendations.
- g) Repair type and repair procedure limitations.
- h) Time delay before final inspection, when required.

10.3.5 Essential Variables

10.3.5.1 General

A repair procedure shall be reestablished as a new repair procedure and shall be requalified when any of the essential variables listed in 5.4.2 or the following are changed. Changes other than those given in 5.4.2 or below may be made without the need for requalification, provided the repair procedure is revised to show the changes.

10.3.5.2 Location of Excavation

Location changes requiring requalification are as follows:

- a) a change from centerline to fusion line location for excavation of partial thickness repairs,
- b) a change from centerline to fusion line location for cover pass repairs.

10.3.5.3 Type of Repair

Any change from a repair type listed in 10.3.2 to another, except when changing from a full thickness repair to either an internal or external partial thickness repair.

10.3.5.4 Preheat and Interpass Temperature

A decrease in the specified minimum preheat temperature used during repair procedure qualification. The addition or change in the interpass temperature requirements used to weld the test joint.

10.3.6 Welding of Test Joints

Repair procedures shall be qualified on a test weld completed following the details of the production welding procedure specification. The repair procedure shall be qualified in the fixed position on a segment of a full-circumference test weld for each repair type to be qualified in the location(s) specified by the company. The repair weld shall be a minimum of 8 in. (203 mm) in length to provide the necessary weld deposit length for destructive testing without Charpy impact tests. A single test joint may be used to qualify more than one type of repair procedure. Details for each repair procedure shall be recorded with the complete results and circumferential location of each repair. Qualification of repair procedures may be required in the presence of the company.

10.3.7 Testing of Repair Welds

10.3.7.1 Tensile, Nick Break, and Bend Tests

The test specimen preparation, test method, and acceptance requirements in 5.6 or 5.8 are appropriate for repair welds, except that test specimens shall be cut from the joint at each of the repair area locations. Weld reinforcement on tensile test specimens shall not be removed for cover pass repairs.

10.3.7.2 Macrosection/Hardness Tests

10.3.7.2.1 Preparation

Transverse sections shall be cut suitable for visual examination of the weld and adjacent base metal, and for a hardness survey. The transverse macrosection test specimens for hardness tests should be at least $\frac{1}{2}$ in. (13 mm) wide. They may be machine cut, or they may be oxygen cut oversized and machined by a nonthermal process to remove at least $\frac{1}{4}$ in. (6 mm) from the side(s) that will be prepared. For each macrosection test specimen, at least one face should be ground and polished to at least 600 grit finish and etched with a suitable etchant, such as Nital, ammonium persulfate or dilute hydrochloric acid to give a clear definition of the weld structure.

10.3.7.2.2 Visual Examination

The macrosections shall be visually examined with lighting that will sufficiently reveal the details of the weld soundness. The use of optical devices or dye penetrants is not necessary.

A visual examination of the macrosections shall show that the repair weld portion of the completed weld is completely fused to the adjacent base metal and/or weld metal at the root and between weld passes and is free of cracks. Any defects shall be within the applicable individual size limits specified in Section 9. If a cross section shows defects that are not associated with the repair weld portion of the completed weld, an additional cross section shall be evaluated. If the additional cross section contains other defects, the qualification test is unacceptable.

10.3.7.3 Hardness Testing

Macrosection test specimens shall be prepared for hardness testing in accordance with ASTM E384. The minimum required number of indentations shall be made using a Vickers indenter and a 10-kg load, or less at locations shown

in Figure 21 through Figure 26, or made at locations otherwise specified at the discretion of the company. HAZ hardness impressions shall be entirely within the HAZ and located as close as possible to the fusion boundary (between the weld metal and HAZ). If subsequent repairs (e.g. double repair) are qualified, the company shall provide hardness test locations.

Maximum hardness values for repair welds shall not exceed those given in Table 6 unless otherwise specified by the company.

NOTE When hardness testing is required, chemical analysis is performed to determine the carbon equivalent of the base materials.

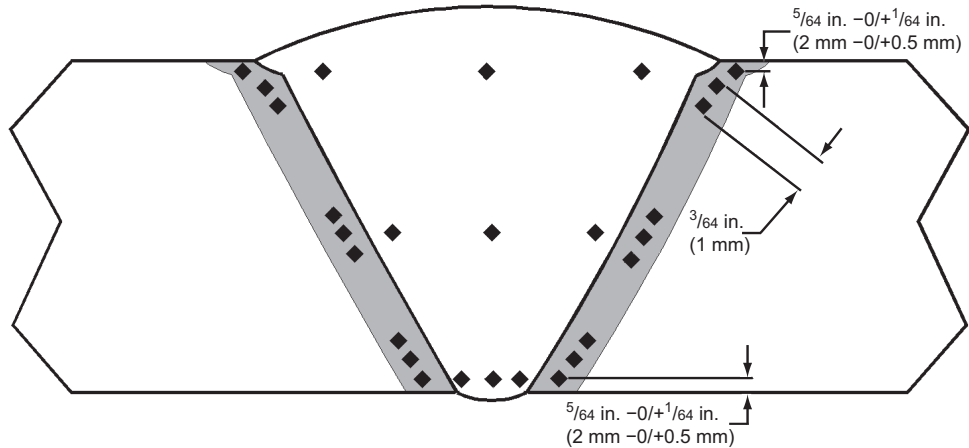

NOTE Heat-affected zone (HAZ) hardness impressions must be entirely within the HAZ and located as close as possible to the fusion boundary (between the weld metal and HAZ).

Figure 21—Hardness Locations for Full Thickness Repair Procedure Qualification

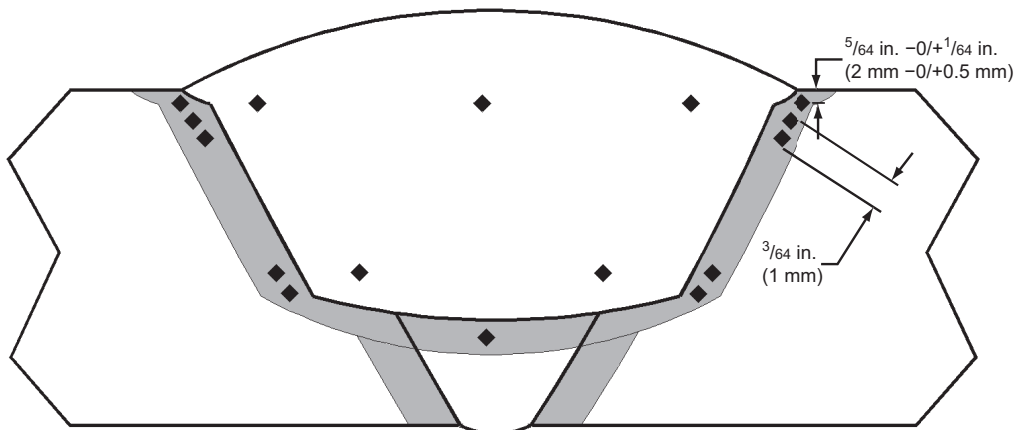

NOTE Heat-affected zone (HAZ) hardness impressions must be entirely within the HAZ and located as close as possible to the fusion boundary (between the weld metal and HAZ).

Figure 22—Hardness Locations for Partial Thickness Repair Procedure Qualification at Weld Centerline

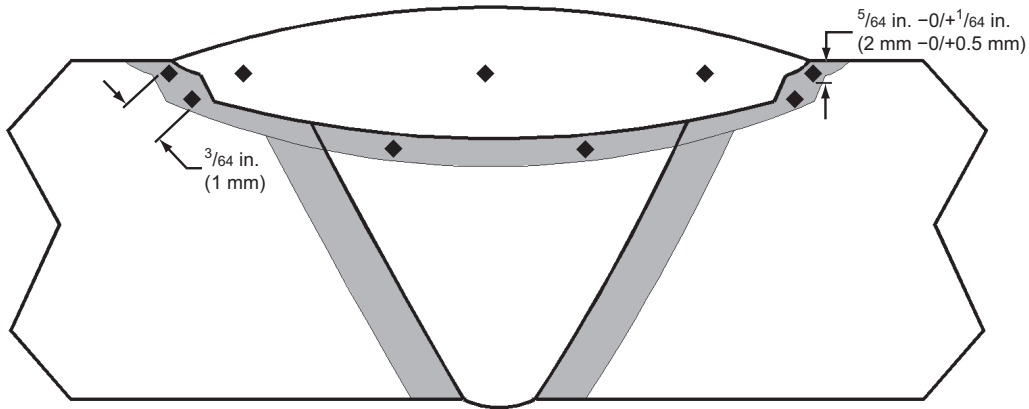

NOTE Heat-affected zone (HAZ) hardness impressions must be entirely within the HAZ and located as close as possible to the fusion boundary (between the weld metal and HAZ).

Figure 23—Hardness Locations for Cover Pass Repair Procedure at Weld Centerline

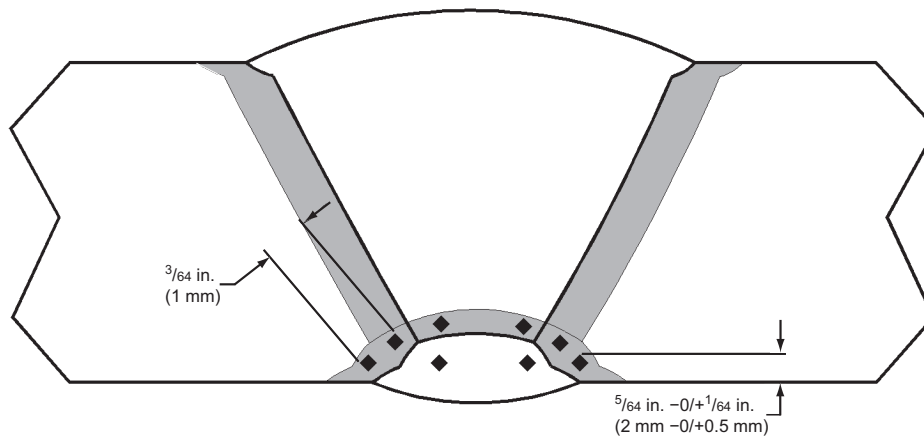

NOTE Heat-affected zone (HAZ) hardness impressions must be entirely within the HAZ and located as close as possible to the fusion boundary (between the weld metal and HAZ).

Figure 24—Hardness Location for Back Weld Repair or Internal Partial Thickness Repair Procedure at Weld Centerline

10.3.7.4 Impact Tests

10.3.7.4.1 General

When required by 10.3.3, Charpy impact testing shall be performed at locations in the weld as specified by the company.

10.3.7.4.2 Preparation

For each repair procedure, both the weld metal and the HAZ shall be tested. Each test (of weld metal or HAZ) shall consist of at least three valid specimen tests performed at or below the minimum design temperature. The exact size of the specimens depends on the weld thickness but the largest possible size shall be selected. The specimens shall be machined, notched, and tested in accordance with ASTM E23. The notch shall be oriented in the through-thickness direction.

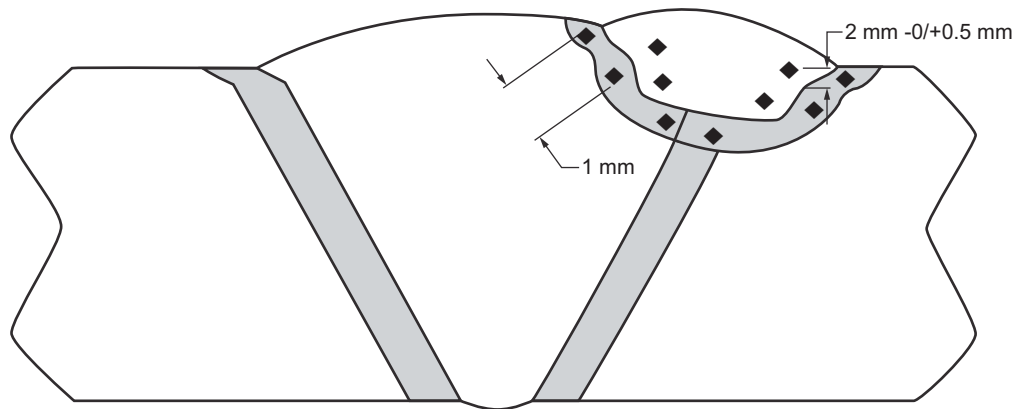

NOTE HAZ hardness impressions shall be entirely within the heat-affected zone and located as close as possible to the fusion boundary (between the weld metal and heat-affected zone).

Figure 25—Hardness Locations for Cover Pass Repair Procedure at Fusion Line

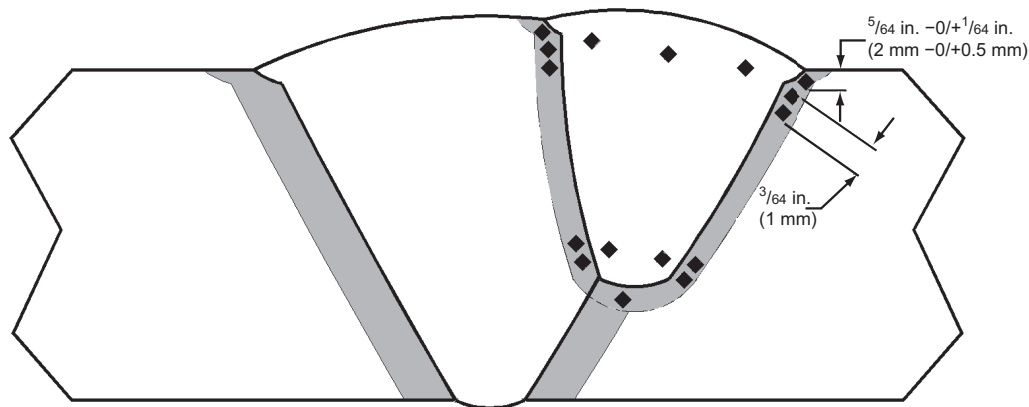

NOTE Heat-affected zone (HAZ) hardness impressions must be entirely within the HAZ and located as close as possible to the fusion boundary (between the weld metal and HAZ).

Figure 26—Hardness Locations for Partial Thickness Repair at Fusion Line

10.3.7.4.3 Requirements

The minimum average value and minimum individual value of impact energy for each set of three specimens when tested at the minimum design temperature shall not be less than the minimum values specified for qualification of the production weld or as otherwise specified by the company.

10.4 Repair Welder Qualification

10.4.1 General

The repair weld shall be made by a qualified welder experienced in methods used for repair of a defective weld. The welder shall be qualified according to the requirements of 6.2 or 6.3 in addition to the requirements of this section.

When a repair procedure is required by 10.2, a welder shall be qualified using the applicable qualified repair procedure. Welders shall be qualified using a completed weld to make a repair weld following all the details of the repair procedure. The repair weld shall be deposited in the fixed position on a segment of a full-circumference test weld for each repair type to be qualified in the location(s) specified by the company. The repair weld shall be a minimum of 8 in. (203 mm) in length to provide the necessary weld deposit for destructive testing. A single completed weld may be used to qualify more than one type of repair.

Table 6—Repair Weld Maximum Hardness Values, HV10 ^a

Hardness Location	Weld Metal		Heat-affected Zone	
	Root and Midthickness	Cap	Root and Midthickness	Cap
Sour service, any welding process	Note b	Note b	Note b	Note b
Non-sour service, any welding process	275 ^c	275	275	325
Non-sour service, low-hydrogen welding process	275	275	350	350

NOTE The company may specify other maximum hardness values.

^a A lower load may be used for the narrow heat-affected zones in some welds made by mechanized or automatic processes.

^b For sour service, see applicable governing standard or specification document.

^c 300 HV10 material 0.375 in. (9.5 mm) thick and above.

Details of the repair welder qualification shall be recorded and maintained with the complete results of the qualification test for each type and location of repair to meet the requirements of 6.8.

10.4.2 Testing of Repairs

For a repair welder qualification test weld, the repair weld shall meet the visual examination requirements of 6.4 and 10.3.7.2.

The destructive testing requirements in 6.5 are for qualification of a repair welder, except that test specimens shall be cut from the joint at each individual repair area location for each type of repair. The total number of specimens and the test to which each shall be submitted are shown in Table 7. As noted in Table 7, when wall thickness is over 0.500 in. (12.7 mm), the side bend tests shall be substituted for face bend or root bend tests.

Table 7—Type and Number of Butt Weld Test Specimens per Repair Type for Repair Welder Qualification

Repair Type	Tensile Strength	Nick Break ^b	Root Bend	Face Bend	Side Bend	Total (Minimum)
Full thickness	0	2	1 ^a	1 ^a	0	4
Internal partial thickness	0	2	1 ^a	0	0	3
External partial thickness	0	2	0	1 ^a	0	3
Cover pass	0	2	0	1 ^a	0	3
Back weld	0	2	1 ^a	0	0	3

^a Side bend tests are substituted for face bend or root bend tests when wall thickness is over 0.500 in. (12.7 mm).

^b One nick break specimen is taken at the transition between the repair weld end and original weld bead and the second nick break specimen located at the midpoint of the repair weld deposit.

A welder who fails to pass the repair welder qualification test(s) shall be permitted to retest as described in 6.7.

10.4.3 Qualification Limits

A repair welder who has successfully completed the qualification test described in 10.4.3 shall be qualified within the limits of the essential variables described below. If any of the following essential variables are changed, the repair welder using a repair procedure shall be requalified:

- a) any change from one repair type to another, except when changing from a full thickness repair to any partial thickness repair;
- b) a change in filler metal group (see Table 1);
- c) an increase in depth of the repair area greater than two times the deposited repair weld thickness in the repair welder qualification test;
- d) a change in position from that for which the repair welder has already qualified (e.g. a change from flat to vertical or a change from vertical to horizontal or vice versa), except overhead position qualifies for all positions.

10.5 Supervision

The repair shall be made under the supervision of an individual acceptable to the company who is experienced and knowledgeable in methods and procedures used for repairs.

Inspection of repairs shall be performed as specified by the company. Welding inspection personnel shall meet the requirements of 8.3.

Repairs shall be documented and maintained by the company.

10.6 Acceptance Criteria

Repaired areas shall be inspected and evaluated by the same NDT methods previously used to determine a defect. Visual inspection is considered adequate when the defect was rejected by visual means and repaired by grinding without additional welding. NDT of a repair weld includes as a minimum the total repair area plus 10 % of the total repair weld length, or 2 in. (50 mm); whichever is longer on each side of the repair area. Repairs shall be considered acceptable when the repair area meets the standards of acceptability of Section 9 or more stringent acceptance criteria specified by the company.

NOTE A repair weld of a weld originally inspected and rejected using alternative acceptance criteria derived in accordance with Annex A must be reinspected and meet the standards of acceptability of Section 9 or more stringent acceptance criteria as specified by the company. Repair of the total length of defect(s) rejected by Annex A alternative acceptance criteria is required. A partial length repair of a defect is prohibited.

11 Procedures for Nondestructive Testing (NDT)

11.1 Radiographic Test Methods

11.1.1 General

Section 11.1 presents the requirements for producing radiographic images on film or other media through the use of X-rays or gamma rays. A detailed procedure for the production of images shall be established and recorded. Radiographic film produced by the use of this procedure shall have the density (see 11.1.10), clarity, and contrast required by this standard. Images produced by other systems shall have the requisite sensitivity to define clearly the essential wire diameter of the proper image quality indicator (IQI). The following criteria shall be used to evaluate images:

- a) an acceptable image quality that is free from fog and from processing irregularities that could mask the image of actual imperfections,

- b) the prescribed IQI and the essential wire diameter,
- c) a satisfactory identification system,
- d) an acceptable technique and setup,
- e) compatibility with acceptance standards.

All requirements that refer to the quality of the resulting images shall apply equally to X-rays and gamma rays. The use of radiographic testing and the frequency of its use shall be at the option of the company.

The company and the radiographic contractor should agree on the radiographic procedure or procedures to be used prior to the performance of production radiography. The company shall require the contractor to demonstrate that the proposed procedures produce acceptable images and shall require the contractor to use such procedures for production radiography.

11.1.2 Details of Procedure

11.1.2.1 General

The details of each radiographic procedure shall be recorded. A copy of the record shall be furnished to the company for its records. The record may be in the form of writing, a sketch, or both. As a minimum, each procedure shall include the applicable details listed in 11.1.2.2 and 11.1.2.3.

11.1.2.2 Film Radiography

As a minimum, the procedure for film radiography shall include the following details.

- a) Radiation source—The type of radiation source, the size of the effective source or focal spot, and the voltage rating of the X-ray equipment.
- b) Intensifying screens—The type and placement of the screens and, if lead is used, their thickness.
- c) Film—The film brand or type or both and the number of film in the holder or cassette. For multiple-film techniques, the way in which the film is to be viewed shall be specified.
- d) Exposure geometry—Whether single-wall exposure for single-wall viewing (SWE/SWV), double-wall exposure for single-wall viewing (DWE/SWV), or double-wall exposure for double-wall viewing (DWE/DWV); the distance from the source or focal spot to the film; the relative positions of the film, weld, source, IQIs, and interval or reference markers; and the number of exposures required for radiography of a complete weld.
- e) Exposure conditions—Whether milliamperes or curie minutes, the X-ray voltage or the input voltage and amperage, and the exposure time.
- f) Processing—Whether automatic or manual; the time and temperature for development and the time for stop bath or rinsing, fixing, and washing; and drying details.
- g) Materials—The type and thickness range of material for which the procedure is suitable.
- h) IQIs—The type of material, identifying ASTM or ISO set, and essential wire diameter.
- i) Heat shields—Material, thickness, and the distance from the film side of the heat shield to the pipe surface.

11.1.2.3 Other Imaging Media

As a minimum, the procedure for radiography using imaging media other than film shall include the following details.

- a) Radiation source—The type of radiation source, the size of the effective source or focal spot, and the voltage rating of the X-ray equipment.
- b) The image collection system used.
- c) The image processing system used.
- d) The image viewing system used.
- e) The image storage system used.
- f) Exposure geometry—Whether SWE/SWV, DWE/SWV, or DWE/DWV; whether in motion or still imaging; the scanning speed for in motion imaging; the distance from the source or focal spot to the imager surface; the relative positions of the imager surface, weld, source, IQIs, and the intervals or reference markers; the amount of geometric magnification; the total magnification used for viewing; and the number of images required for radiography of a complete weld.
- g) Exposure conditions—Whether milliamperere or curie minutes, the X-ray voltage or the input voltage and amperage, and when applicable, the exposure time.
- h) Materials—The type and thickness range of material for which the procedure is suitable.
- i) IQIs—The type of material, identifying ASTM or ISO set, and essential wire diameter.
- j) Heat shields—Material, thickness, and the distance from the imaging side of the heat shield to the pipe surface.

11.1.3 Exposure Geometry

11.1.3.1 Film Radiography

When a radiographic source is centered in the pipe for exposing a butt weld, one exposure is adequate for the radiographic testing of the complete weld (SWE/SWV). When the radiographic source is outside but not more than $\frac{1}{2}$ in. (13 mm) from the weld surface, at least three exposures separated by 120° shall be made for the radiographic testing of a complete weld (DWE/SWV). When the radiographic source is outside and more than $\frac{1}{2}$ in. (13 mm) from the weld surface, at least four exposures separated by 90° shall be made for the radiographic testing of a complete weld (DWE/SWV). When the OD of the piping containing the weld is 3.500 in. (88.9 mm) or less, a DWE/DWV procedure may be used. When this procedure is used and the radiation beam is offset so that the source-side and film-side portions of the weld do not overlap in the areas of the radiograph being evaluated, at least two exposures separated by 90° shall be made for the radiographic testing of a complete weld. When the source-side and film-side portions of the weld are superimposed, at least three exposures separated by 60° shall be made for the radiographic testing of a complete weld.

When smaller diameter, thicker wall pipe is radiographed, additional exposures should be made to minimize the distortion of imperfection images at the ends of the radiographs.

The minimum distance between the source or focal spot and the source side of the object being radiographed shall be determined by the following formula (using constant units of measurement):

$$D = St/k$$

where

- D is the minimum distance, in inches (mm), between the source or focal spot and the source side of the object being radiographed;
- S is the size, in inches (mm), of the effective source or focal spot;
- t is the thickness of the weld, in inches (mm), including reinforcement, plus the distance between the film side of the weld and the film;
- k is the geometric unsharpness factor.

When t is determined for SWE/SWV and DWE/SWV procedures, the thickness of the single wall and its weld reinforcement shall be used. When t is determined for DWE/DWV procedures, the OD of the weld (i.e. the OD of the pipe plus twice the average height of the weld crown) shall be used; k is defined as 0.02 in. (0.5 mm) for material with a thickness of less than or equal to 2.000 in. (50.8 mm).

11.1.3.2 Other Imaging Media

For in-motion imaging, the exposure geometry shall be evaluated at the maximum scanning speed to be used during the radiographic testing of the complete weld.

11.1.4 Type of IQIs

IQIs shall conform to the requirements of either ASTM E747 or ISO 19232-1 wire IQI. The company shall define which type of IQI (ASTM or ISO) is to be used. The IQI shall be made of a material that is radiographically similar to the material being welded.

11.1.5 Selection of IQIs

The IQI shall consist of either a series of six (6) wires for ASTM E747 wire type or a series of seven (7) wires for ISO 19232-1 wire type IQI, arranged in order of increasing diameter. The essential wire diameter to be used, based on the thickness of the weld is shown in Table 8 for ASTM E747 wire type IQI and Table 9 for ISO 19232-1 wire type IQI. At the option of the company, smaller wire diameter IQI than those specified above may be used, provided the required radiographic sensitivity is obtained. The radiographic images of the IQI identifying style number and ASTM set letter or ISO designation shall appear clearly. The image of the essential wire diameter shall appear clearly across the entire area of interest.

NOTE For purposes of IQI selection, when the SWE/SWV or DWE/SWV technique is used, the thickness of the weld means specified wall thickness plus the weld reinforcement (internal plus external combined). When the "elliptical" DWE/DWV technique is used, the thickness of the weld means twice the specified wall thickness plus the single weld reinforcement (internal plus external combined). When the "superimposed" DWE/DWV technique is used, the thickness of the weld means twice the specified wall thickness plus twice the weld reinforcement (internal plus external combined).

Table 8—Weld Thickness vs Diameter of ASTM E747 Wire Type IQI

Weld Thickness		Essential Wire Diameter		ASTM Set Letter
in.	mm	in.	mm	
0 to 0.250	0 to 6.4	0.008	0.20	A
>0.250 to 0.375	>6.4 to 9.5	0.010	0.25	A or B
>0.375 to 0.500	>9.5 to 12.7	0.013	0.33	B
>0.500 to 0.750	>12.7 to 19.1	0.016	0.41	B
>0.750 to 1.000	>19.1 to 25.4	0.020	0.51	B
>1.000 to 2.000	>25.4 to 50.8	0.025	0.64	B

Table 9—Weld Thickness vs Diameter of ISO Wire Type IQI

Weld Thickness		Essential Wire Diameter		Wire Identity
in.	mm	in.	mm	
0 to 0.250	0 to 6.4	0.008	0.20	13
>0.250 to 0.375	>6.4 to 9.5	0.010	0.25	12
>0.375 to 0.500	>9.5 to 12.7	0.013	0.33	11
>0.500 to 0.750	>12.7 to 19.1	0.016	0.41	10
>0.750 to 1.000	>19.1 to 25.4	0.020	0.51	9
>1.000 to 2.000	>25.4 to 50.8	0.025	0.64	8

11.1.6 Placement of IQIs

11.1.6.1 Film

The IQIs shall be placed as follows.

- a) When a complete weld is radiographed in a single exposure using a source inside the piping, at least four IQIs placed across the weld and spaced approximately equally around the circumference shall be used. For the DWE/DWV procedure, one IQI shall be placed on the source side of the pipe and across the weld so that the essential wire image is superimposed onto the weld images. For the DWE/SWV or SWE/SWV procedures requiring multiple exposures or multiple films for complete inspection of the weld, and where the length of film to be interpreted is greater than 5 in. (130 mm), two IQIs placed across the weld and located on the film side shall be used. One shall be within 1 in. (25 mm) of the end of the film length to be interpreted and the other shall be at the center of the film. When the film length to be interpreted is 5 in. (130 mm) or less, one IQI shall be placed on the film side, across the weld and located at the center of the length to be interpreted. When a repaired weld is radiographed, an additional IQI shall be placed across each repaired area.
- b) When it is not practical to place an IQI on the weld due to weld configuration or size, the IQI may be placed on a separate block. Separate blocks shall be made of the same or radiographically similar material and may be used to facilitate IQI positioning. The thickness of the separate block material should be the same as the thickness of the weld.
- c) Heat shields—IQI may be placed on a heat shield rather than in contact with the pipe, provided that the acceptability of such IQI placement is demonstrated during procedure qualification.

11.1.6.2 Other Imaging Media

For imaging media other than film, IQI placement shall be the same as that required by 11.1.6.1. The IQI may be placed above the surface of the pipe or held in position between the surface of the pipe and the imager by a fixture attached to the imager or scanning device. Acceptability of such IQI placement shall be demonstrated during procedure qualification.

11.1.7 Production Radiography

Only Level II or III radiographers shall interpret the radiographic images of production welds. Radiographers shall report to the company all defects observed in the images unless the company requires that all imperfections observed be reported. The radiographer shall indicate whether the weld meets the requirements of Section 9. The company shall determine the final disposition of the weld.

11.1.8 Identification of Images

Images shall be clearly identified by the use of lead numbers, lead letters, markers, or other identification so that the proper weld and any imperfections in it can be quickly and accurately located. The company may specify the identification procedure to be used. Whenever more than one image is used to inspect a weld, identification markers shall appear on each image and adjacent images shall overlap. The last reference marker on each end of the image shall appear on the appropriate adjacent images in a way that establishes that no part of the weld has been omitted.

11.1.9 Storage of Film and Other Imaging Media

11.1.9.1 Film

All unexposed films shall be stored in a clean, dry place where the conditions will not detrimentally affect the emulsion. If any question arises about the condition of the unexposed film, sheets from the front and back of each package or a length of film equal to the circumference of each original roll shall be processed in the normal manner without exposure to light or radiation. If the processed film shows fog, the entire box or roll from which the test film was removed shall be discarded, unless additional tests prove that the remaining film in the box or roll is free from preexposure fog exceeding 0.30 H&D transmitted density for transparent-based film or 0.05 H&D reflected density for opaque-based film.

NOTE H&D refers to the Hurter-Driffield method of defining quantitative blackening of the film. (Ferdinand Hurter and Vero Charles Driffield, "Photochemical Investigations and a New Method of Determination of the Sensitiveness of Photographic Plates," *J. Soc. Chem. Ind.*, May 31, 1890.)

11.1.9.2 Other Imaging Media

Imaging media other than film shall be stored in strict accordance with the manufacturer's recommendations.

11.1.10 Film Density

11.1.10.1 General

Except for small localized areas caused by irregular weld configurations, the transmitted H&D density in the area of interest of transparent-based film shall not be less than 1.8 or greater than 4.0. The reflected H&D density for opaque-based film shall not be less than 0.5 nor greater than 1.5. Transmitted H&D densities through small localized areas may exceed these limits; however, minimum densities shall not be less than 1.5 and maximum densities shall not exceed 4.2; reflected H&D density shall not be less than 0.25 and shall not exceed 1.8.

NOTE H&D refers to the Hurter-Driffield method of defining quantitative blackening of the film. (Ferdinand Hurter and Vero Charles Driffield, "Photochemical Investigations and a New Method of Determination of the Sensitiveness of Photographic Plates," *J. Soc. Chem. Ind.*, May 31, 1890.)

11.1.10.2 Film Viewing Equipment

The viewing equipment (illuminator) shall be of the variable high intensity type and shall be capable of viewing film densities within the range specified in 11.1.10.1. It shall be equipped to prevent light, coming from around the outer edge of the radiograph or through low density portions of the radiograph, from interfering with interpretations.

11.1.10.3 Film Viewing Facilities

Viewing facilities shall provide subdued background lighting of an intensity that will not cause troublesome reflections, shadows, or glare on the radiograph.

11.1.10.4 Image Processing

When requested by the company, film or other imaging media shall be processed, handled, and stored so that the images are interpretable for at least three years after they are produced.

11.1.10.5 Image Processing Area

The image processing area and all accessories shall be kept clean at all times.

11.1.10.6 Radiation Protection

The radiographer shall be responsible for the protection and monitoring of every person working with or near radiation sources. The protection and monitoring shall comply with applicable federal, state, and local regulations.

11.2 Magnetic Particle Test Method

When magnetic particle testing is specified by the company, a detailed written procedure for magnetic particle testing shall be established that meets the requirements of ASTM E709. The company and the NDT contractor should agree on the magnetic particle testing procedure or procedures prior to the performance of production testing.

The company shall require the contractor to demonstrate that the proposed procedures will produce acceptable results and shall require the contractor to use such procedures for production testing.

11.3 Liquid Penetrant Test Method

When liquid penetrant testing is specified by the company, a detailed written procedure for liquid penetrant testing shall be established that meets the requirements of ASTM E165. The company and the NDT contractor should agree on the liquid penetrant testing procedure or procedures prior to the performance of production testing.

The company shall require the contractor to demonstrate that the proposed procedures will produce acceptable results and shall require the contractor to use such procedures for production testing.

11.4 Ultrasonic Test Methods

11.4.1 General

When ultrasonic testing is specified by the company for the inspection of new and/or in-service circumferential butt welds, the requirements of this section shall apply. A detailed procedure for use of the individual ultrasonic techniques shall be established and recorded. The use of ultrasonic testing and the scope of its use shall be at the option of the company.

The company and the ultrasonic contractor should agree on the ultrasonic procedures before the performance of production testing. The company shall require the ultrasonic contractor to demonstrate the proposed procedures to produce acceptable and accurate results and shall require the contractor to use such procedures for production testing.

Caution is advised when this method is applied to in-service weld inspection due to potential parent material and surface imperfections that can interfere with the use of the ultrasonic technique.

All surfaces to be ultrasonically scanned shall be in the uncoated condition. For new construction projects, the coating cutback (bare pipe length) at pipe ends necessary for ultrasonic scanning should be specified prior to the pipe being coated. Pipe seams should be ground flush with the pipe surface for the distance necessary for ultrasonic scanning.

11.4.2 Details of Procedure

11.4.2.1 General

The details of each ultrasonic procedure shall be recorded. A copy of the record shall be furnished to the company for its records. The record shall be in the form of both writing and sketches. As a minimum, each procedure shall include the applicable details listed in 11.4.2.2.

11.4.2.2 Ultrasonic Procedure

As a minimum the procedure for ultrasonic testing of welds shall include the following specific application details.

- a) Type of welds to be tested, joint preparation dimensions, and welding processes.
- b) Material type (i.e. size, grade, thickness, process of manufacturing per API 5L).
- c) Scanning surface preparation/condition.
- d) Stage at which examination is to be performed.
- e) Ultrasonic instrument/system and probes (i.e. manufacturer, type, size, etc.).
- f) Automatic or manual.
- g) Couplant.
- h) Testing technique:
 - 1) angles,
 - 2) frequencies (MHz),
 - 3) temperatures and ranges,
 - 4) scanning patterns and speeds,
 - 5) reference datum and location markers (i.e. root face and circumferential locations).
- i) Reference standards—detail sketches showing plan view and cross-section view dimensions of production material reference standard blocks and all reference reflectors.
- j) Calibration requirements—the interval at which calibration of the instrument or system is required, the sequence of setup calibration prior to inspecting welds, including all standard calibration blocks to be used, the reference sensitivity reflectors to be used, the reference sensitivity-level setting [i.e. distance amplitude correction (DAC) or time-corrected gain (TCG)], and the intervals for verification of calibration settings.
- k) Scanning level—the sensitivity setting in decibels (dB) to be added to the reference sensitivity for scanning.
- l) Evaluation level—the level or height of echoes detected during scanning at which further evaluation is required and any sensitivity adjustment to be made before evaluating for acceptance or rejection.
- m) Recording of results—type of record (e.g. sketch, thermal printer, compact disc, etc.) and whether all reflectors or only unacceptable reflectors will be recorded.
- n) Ultrasonic examination report—an example of the examination reports.

11.4.3 Ultrasonic Testing Personnel Requirements

An NDT Level III in the ultrasonic method shall develop the application technique and prepare and approve the testing procedure. Only Level II or III certified personnel shall calibrate equipment and interpret the test results. NDT Level II or III personnel in ultrasonics shall perform the test and evaluate the results per the acceptance/rejection criteria.

The ultrasonic testing personnel shall perform examinations in accordance with qualified and approved procedures (see 11.4.4). Personnel responsible for testing shall be capable of determining the acceptability of circumferential butt welds in accordance with the acceptance criteria as listed in 9.6.

The company has the right, at any time, to require personnel to demonstrate their capabilities to perform to the requirements of the qualified procedure.

11.4.4 Demonstration of the Testing Procedure

Prior to final written approval, the company shall require the contractor to demonstrate the application of the procedure and ultrasonic systems. A procedure demonstration report shall be generated and the results documented prior to use on actual field welds. The demonstration process shall be as follows.

- a) Welds containing defects and acceptable imperfections shall be prepared from actual production pipe material samples utilizing an approved welding procedure specification. Changes in wall thickness, bevel design, acoustic velocity, welding process, repair welds, and other variables that can have an effect on the detectability and resolution of the system shall require additional demonstration welds from other corresponding approved welding procedures. Welder qualification welds may be used.
- b) Radiographs shall be made of the welds and the results documented.
- c) The ultrasonic testing procedure shall be applied, within the detailed temperature ranges, and the results documented and compared with the radiographs.
- d) Differences in detection results shall be documented. (Differences in detectability and resolution between ultrasonics and radiography shall be noted.) If required by the company, destructive testing of the weld sample shall be made to discover or confirm the results.
- e) Use of the ultrasonic testing procedure on production welding shall be based on the capability of the implemented ultrasonic testing method/technique/systems to:
 - 1) circumferentially locate,
 - 2) size for length,
 - 3) determine depth from OD surface, and
 - 4) axially (weld cross section) locate required imperfections/defects in the test samples.

In addition, the procedure shall accurately determine the acceptability of welds in accordance with the criteria listed in 9.6 and 11.4.7.

11.4.5 API Sensitivity Reference Standard

Manual ultrasonic testing sensitivity shall be based on a two or three point reference level (i.e. DAC or TCG) derived from an N10 notch introduced into a sample of the pipe to be inspected (see Figure 27 and Figure 28). The highest point of the DAC/TCG shall not be less than 80 % of full screen height. The reference standard shall also be used to determine the actual sound beam velocity, refracted angle, and sound path distance in the pipe material to be

inspected. Unknown velocity and refracted angle shall be determined when welds in pipe of different chemistry specifications, wall thickness, diameter or from more than one pipe and rolling or piercing manufacturer are to be inspected. This may be accomplished by using two probes of the same nominal angle and frequency with the probes directed toward one another (see Figure 29). When a difference is noted in velocity, angle, or sound path distance, another reference standard shall be made from the different pipe material.

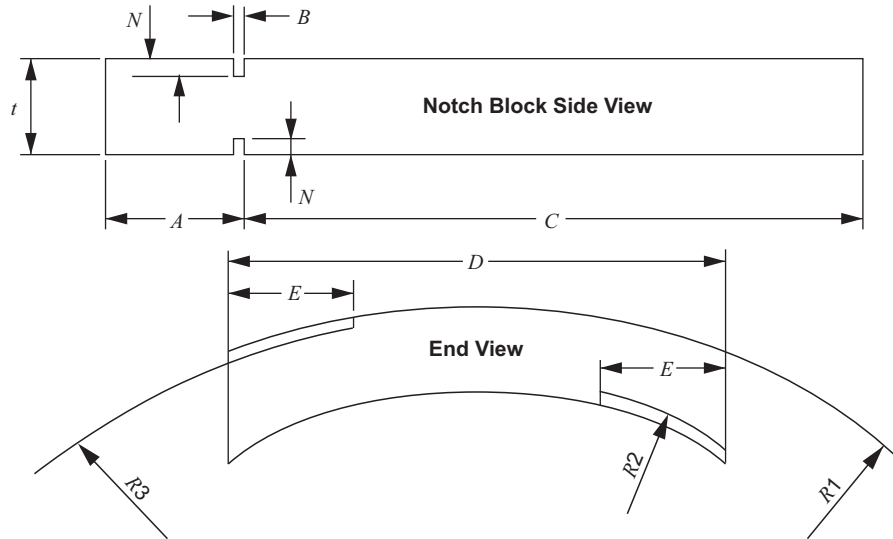

Dimensions

t	Specified pipe wall thickness
N	Notch depth = $10\%T \pm 10\%$ of notch depth
A	2 in. (50 mm) minimum length
B	0.125 in. (3.2 mm) maximum notch width
C	$11.35T + 2$ in. (50 mm) minimum length
D	3.1 in. (80 mm) minimum width
E	1 in. (25 mm) minimum notch length
$R1$	Outside radius of pipe
$R2$	Radius of inside notch = $R1 - 0.9T$

Figure 27—Reference Block for Manual Ultrasonic Testing

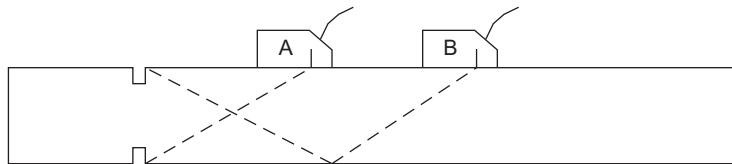

Position the transducer in line with the outside notch at double the distance used to peak up the inside notch (Position B). Verify that the outside notch echo peak is at or near zero depth reading. This will establish that refracted angle and velocity settings are sufficiently accurate.

Figure 28—Establishing Distance, Refracted Angle, and Velocity

For automatic ultrasonic testing and when required by the company for manual ultrasonic testing, flat bottom holes shall be machined into a sample of the pipe to be inspected. This sample shall be used as calibration reflectors in addition to the N10 notches at the inside and outside surfaces. The diameter of each flat bottom hole should be approximately equal to the thickness of one welding fill pass. The flat reflecting surface of each hole shall be installed

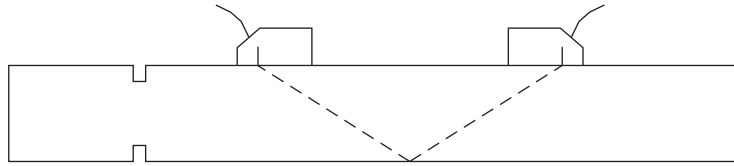

Using two transducers of equal angle and frequency, one transmitting and the other receiving, maximize (peak up) the echo received. Measure the surface distance between the transducer exit points. Half the surface distance divided by measured wall thickness equals the refracted angle tangent. Without changing instrument settings, repeat this process on pipe with unknown velocity, refracted angle, and attenuation to determine any differences.

Figure 29—Transfer Procedure

at the same angle and position as the weld joint preparation for each fill pass required by the welding procedure. Additionally, planar reflectors or flat bottom holes shall be installed at the weld centerline position with their flat reflecting surfaces vertical to the weld. All reflectors should be spaced apart so that no two will be within the beam spread of one probe simultaneously.

For testing on other than new construction, a pipe sample of the same grade, wall thickness, and OD as the pipe to be inspected shall be used to make the reference standard. A transfer technique using probes of the same nominal angles and frequencies to be used for inspection shall be carried out to determine actual full skip distance, actual refracted angle, and attenuation in the material to be inspected (see Figure 29).

11.4.6 Parent Material Ultrasonic Testing

After completion of the circumferential butt weld, but prior to its ultrasonic testing, a compression wave test of the parent material on both sides of the weld (minimum distance = 1.25, the longest surface skip distance to be used) shall be performed. All interfering partial and full beam reflectors shall be noted (datum location and distance from the weld edge) and recorded on the examination record.

The company may elect to waive this requirement in lieu of lamination checks performed by the mill.

11.4.7 Scanning and Evaluation Level

11.4.7.1 Parent Material Ultrasonic Testing

Manual compression wave testing of parent material shall be performed with the second backwall echo from the reference standard (see Figure 27) adjusted to at least 80 % of full screen height.

Automatic ultrasonic testing of the parent material shall be performed by using the same calibration method and evaluation level as that used for manual compression wave or by a different technique if demonstrated to be equal to or better than the manual method.

11.4.7.2 Manual Ultrasonic Weld Testing

Manual ultrasonic weld testing shall be performed at a scanning sensitivity of DAC/TCG reference sensitivity plus 6 dB minimum. All indications that exceed 50 % of DAC/TCG screen height shall be evaluated.

Evaluation sensitivity for manual ultrasonic weld testing should be DAC/TCG reference sensitivity plus 6 dB with an evaluation level for all indications at 50 % of DAC/TCG screen height.

After the reference sensitivity, scanning sensitivity, and evaluation sensitivity and levels have been established, they shall be qualified and then incorporated into the final procedure and in the final qualification report.

11.4.7.3 Automatic Ultrasonic Weld Testing

Automatic ultrasonic weld testing should be performed at a scanning sensitivity of 80 % screen height reference sensitivity plus 4 dB when using the pulse-echo technique. Evaluation sensitivity should be the same as scanning sensitivity.

Evaluation level screen height (recording threshold) should be 40 % of full screen height using the automated pulse-echo technique.

Other automated techniques, reference reflectors, reference sensitivities, scanning sensitivities, evaluation sensitivities, and evaluation levels may be used if demonstrated to be equivalent to the pulse-echo technique for the detection and evaluation of weld imperfections.

11.4.8 Production Ultrasonic Testing

Ultrasonic technicians shall report to the company all defects unless the company requires that all observed (evaluation level and above) indications be reported. The company shall determine the final disposition of the weld.

11.4.9 Identification of Reported Indications

The ultrasonic testing report of inspected welds shall include the weld number, datum location, length, depth from the OD surface, and defect classification (linear, transverse, or volumetric) of all reported indications.

12 Mechanized Welding with Filler Metal Additions

12.1 Acceptable Processes

Mechanized welding shall be performed using one or more of the following processes:

- a) submerged arc welding,
- b) gas metal arc welding,
- c) gas tungsten arc welding,
- d) flux-cored arc welding with or without external shielding,
- e) plasma arc welding,
- f) the use of a manual or semiautomatic process combined with one of the mechanized processes listed in this section.

12.2 Procedure Qualification

Before production welding is started, a detailed welding procedure specification shall be established and qualified to demonstrate that welds with suitable mechanical properties (such as strength, ductility, and hardness) and soundness can be made by the procedure. Two pipe lengths, full joints or nipples, shall be joined by following all the details of the welding procedure specification. The quality of the weld shall be determined by both destructive and nondestructive testing and shall meet the requirements of 5.6, except nick breaks (5.6.3) shall not be required, and Section 9, respectively. Should a welding procedure qualification utilize a manual weld or semiautomatic pass as outlined in 12.1, the nick break test in 5.6.3 shall be required as part of the procedure qualification. These procedures shall be adhered to except where a change is specifically authorized by the company, as provided for in 12.5.

12.3 Record

The details of each qualified procedure shall be recorded. This record shall show complete results of the procedure qualification test. Forms similar to those shown in Figure 1 and Figure 2 should be used. This record shall be maintained as long as the procedure is in use.

12.4 Welding Procedure Specification

12.4.1 General

The welding procedure specification shall include all the information that is pertinent to setting up and maintaining the proper operation of the equipment, as well as other information specified in 12.4.2.

12.4.2 Specification Information

12.4.2.1 Process

The specific process or combination of processes used shall be identified. This shall include the type of welding technology and a description of the equipment to be utilized.

12.4.2.2 Materials

The materials to which the procedure applies shall be identified. Materials may be grouped (see 5.4.2.2), provided that the qualification test is made on the material with the highest SMYS in the group.

12.4.2.3 Diameters

The range of specified ODs over which the procedure is applicable shall be identified.

12.4.2.4 Wall Thickness Group and Number and Sequence of Beads

The range of specified wall thicknesses over which the procedure is applicable shall be identified, as shall the range of number of beads required for the thicknesses and the machine used for each bead.

12.4.2.5 Joint Design

The specification shall include a sketch or sketches of the joint that show the type of joint (e.g. V or U), the angle of bevel, and the size of the root face and root opening. If a backup is used, the type shall be designated.

12.4.2.6 Filler Metal and Flux

The size and AWS classification number of the filler metal and flux, if available, shall be designated. For any filler metals with a G suffix designator only, the manufacturer and trade name shall also be designated.

12.4.2.7 Electrical Characteristics

The current and polarity shall be designated, and the range of voltage and amperage for each size or type of electrode used shall be specified.

12.4.2.8 Position

The specification shall designate roll or position welding.

12.4.2.9 Direction of Welding

For position welding only, the specification shall designate whether the welding is to be performed in an uphill or downhill direction.

12.4.2.10 Time Between Passes

The maximum time between the completion of the root bead and the start of the second bead, as well as the maximum time between the completion of the second bead and the start of other beads, shall be designated.

12.4.2.11 Type of Lineup Clamp

The specification shall designate whether the lineup clamp is to be internal or external or if no clamp is required.

12.4.2.12 Cleaning

The specification shall describe the joint end and interpass cleaning required.

12.4.2.13 Preheat

The methods, width to be heated, minimum temperature at the start of the weld, and minimum ambient temperature below which preheat is required shall be specified.

12.4.2.14 PWHT

The methods, width to be heated, minimum and maximum temperature, time at temperature, and temperature control methods for PWHT shall be specified.

12.4.2.15 Shielding Gas and Flow Rate

The composition of the shielding gas and the range of flow rates shall be designated.

12.4.2.16 Shielding Flux

The AWS classification number, if available, or the brand number of the shielding flux shall be designated.

12.4.2.17 Speed of Travel

The range for speed of travel, in in. (mm) per minute, shall be specified for each pass.

12.4.2.18 Method of Cooling After Welding

The type of cooling after welding, such as air cooling or forced cooling with water to expedite nondestructive examination and joint coating, as well as the maximum metal temperature at which forced cooling is applied.

12.4.2.19 Other Factors

Other important factors that may be necessary for proper operation of the process or that may affect the quality of the work produced shall be designated. These may include the location and angle of arc for submerged arc welding, the contact-tube-to-work distance, and the oscillation width and frequency.

12.5 Essential Variables

12.5.1 General

A welding procedure shall be reestablished as a new welding procedure specification and shall be completely requalified when any of the essential variables listed in 12.5.2 are changed. Changes other than those listed in 12.5.2 may be made in the procedure without the need for requalification, provided the welding procedure specification is revised to show the changes.

12.5.2 Changes Requiring Requalification

12.5.2.1 Welding Process

A change from the welding process established in the welding procedure specification constitutes an essential variable.

12.5.2.2 Materials

A change in material constitutes an essential variable. For the purposes of this standard, all carbon steels shall be grouped as follows:

- a) SMYS less than or equal to that of the material specified as API 5L Grade X42;
- b) SMYS greater than that of the material specified as API 5L Grade X42 but less than that of the material specified as API 5L Grade X65;
- c) for carbon steels with a SMYS greater than or equal to that of the material specified as API 5L Grade X65, each grade shall receive a separate qualification test.

NOTE The groupings specified above in 12.5.2.2 do not imply that base materials or filler metals of different analyses within a group may be indiscriminately substituted for a material that was used in the qualification test without consideration of the compatibility of the base materials and filler metals from the standpoint of metallurgical and mechanical properties and requirements for preheat and PWHT.

12.5.2.3 Joint Design

A major change in joint design (e.g. from V groove to U groove) or any change beyond the range established in the welding procedure specification for such factors as spacing, root face, and angle of bevel constitutes an essential variable.

12.5.2.4 Wall Thickness

A change in specified wall thickness beyond the range established in the welding procedure specification constitutes an essential variable.

12.5.2.5 Pipe Diameter

A change in pipe specified OD beyond the range established in the welding procedure specification constitutes an essential variable.

12.5.2.6 Filler Metal

The following changes in filler metal constitute essential variables:

- a) a change from one filler metal group to another (see Table 1);

- b) for any filler metals with a G suffix designator only, a change in the manufacturer or trade name;
- c) for pipe materials with a SMYS greater than or equal to that of the material specified as API 5L Grade X65, any change in the AWS classification of the filler metal (see 12.5.2.2).

NOTE Except as indicated in item b) above, changes in filler metal may be made within the groups specified in 12.5.2.2, items a) and b).

The compatibility of the base material and the filler metal should be considered from the standpoint of mechanical properties.

12.5.2.7 Size of Filler Metal Wire

A change in the size of the filler metal wire constitutes an essential variable.

12.5.2.8 Time Between Passes

An increase in the maximum time between completion of the root bead and the start of the second bead constitutes an essential variable.

12.5.2.9 Direction of Welding

A change in the direction of welding from vertical uphill to vertical downhill, or vice versa, constitutes an essential variable.

12.5.2.10 Shielding Gas and Flow Rate

A change from one shielding gas to another or from one mixture of gases to another constitutes an essential variable. An increase or decrease in the range of flow rates established for the shielding gas also constitutes an essential variable.

12.5.2.11 Shielding Flux

Refer to Table 1, Footnote a, for changes in shielding flux that constitute essential variables.

12.5.2.12 Speed of Travel

A change in the range for speed of travel constitutes an essential variable.

12.5.2.13 Preheat

A decrease in the specified minimum preheat temperature constitutes an essential variable.

12.5.2.14 PWHT

The addition of PWHT or a change from the ranges or values specified in the procedure shall each constitute an essential variable.

12.5.2.15 Electrical Characteristics

A change in electrical characteristics constitutes an essential variable.

12.5.2.16 Orifice Diameter or Orifice Gas Composition

For plasma arc welding, a change in orifice gas nominal composition or a change in orifice diameter.

12.5.2.17 Method of Cooling After Welding

An increase in the maximum weld temperature prior to forced cooling. A change in the method of cooling after welding resulting in a higher rate of cooling also requires requalification of the welding procedure.

12.6 Qualification of Welding Equipment and Operators

12.6.1 General

Each welding operator shall be qualified by producing an acceptable weld using the qualified welding procedure. The completed weld shall be tested by destructive methods, nondestructive methods, or both, and shall meet the requirements of 6.4 through 6.7 except nick breaks (see 6.5.4) shall not be required. Should a welding procedure qualification utilize a manual or semiautomatic pass as outlined in 12.1, the nick break test in 5.6.4 shall be required as part of the welding operator qualification. The tensile strength tests shall not be replaced by nick break tests (see 6.5.2) and thus omitted. Prior to the start of welding, each welding operator shall have received adequate training in the operation of the welding equipment. If the welding procedure involves more than one operation, welding operators shall be qualified on the type of welding equipment that will be used in production welding. Changes in the essential variables described in 12.6.2 require requalification of the welding operator.

12.6.2 Changes Requiring Requalification

Changes in the following essential variables require requalification of the welding operator.

- a) A change from one welding process, mode of transfer, polarity or method of application to another welding process or combination of processes (e.g. short arc, pulse arc, spray arc, gas tungsten arc, etc.).
- b) A change in the direction of welding from vertical uphill to vertical downhill or vice versa.
- c) A change in the filler metal type (solid wire, metal core, flux core).
- d) A change from one specified OD group to another:
 - 1) OD less than 12.75 in (323.9 mm),
 - 2) OD equal to or greater than 12.75 in. (323.9 mm).
- e) Welding operator shall qualify on the heaviest specified wall thickness that the welder/operator will weld in production.
- f) A change in position from that for which the welder/operator has already qualified (e.g. a change from rolled to fixed or a change from vertical to horizontal). A welder who qualifies in the fixed position shall also be qualified to perform rolled welds within the essential variables qualified.
- g) A change in welding bug manufacturer or model.
- h) A change in the method of applying the root bead (e.g. external root versus internal root).
- i) A major change in joint design (e.g. from a V groove to a U groove or J groove) or any change beyond the range established for such factors as spacing, root face, and angle of bevel constitutes an essential variable.

- j) At the option of the company, welders/operators whose work is limited to specific weld passes in a multipass butt weld shall qualify by demonstrating their ability to weld those specific passes in accordance with a qualified welding procedure specification, with the other weld passes necessary to make complete welds being made by others. Welders shall be qualified if all tests are acceptable.

12.7 Records of Qualified Operators

A record shall be made of the tests required by 12.6 and of the detailed results of each test. A form similar to that shown in Figure 2 should be used. (This form should be developed to suit the needs of the company but must be sufficiently detailed to demonstrate that the qualification test meets the requirements of this standard.) A list of qualified operators and the procedures for which they are qualified shall be maintained. An operator may be required to requalify if a question arises about their competence.

12.8 Inspection and Testing of Production Welds

Production welds shall be inspected and tested in accordance with Section 8.

12.9 Acceptance Standards for NDT

The acceptance standards for NDT shall be in accordance with Section 9 or, at the company's option, Annex A.

12.10 Repair and Removal of Defects

Repair and removal of defects shall be in accordance with Section 10.

12.11 Radiographic Testing

Radiographic testing shall be in accordance with 11.1.

12.12 Ultrasonic Testing

Ultrasonic testing shall be in accordance with 11.4.

13 Automatic Welding Without Filler Metal Additions

13.1 Acceptable Processes

Automatic welding without filler metal additions shall be done using the flash butt-welding process.

13.2 Procedure Qualification

13.2.1 Procedure

Before production welding is started, a detailed welding procedure specification shall be established and qualified to demonstrate that welds with suitable mechanical properties (such as strength, ductility, and hardness) and soundness can be made by the procedure. At least two welds shall be made by joining pipe lengths, full joints, or nipples and by following all the details of the welding procedure specification. The quality of the weld shall be determined by both destructive and nondestructive testing and shall meet the requirements of 13.2.3 and 13.9. These procedures shall be adhered to except where a change is specifically authorized by the company, as provided for in 13.5.

13.2.2 Radiography Prior to Mechanical Testing

Each procedure qualification weld shall meet the requirements of 13.9 prior to being submitted for mechanical testing.

13.2.3 Mechanical Testing of Butt-welded Joints

13.2.3.1 General

Mechanical test specimens shall be cut from the weld joint as shown in Figure 30, Figure 31, and Figure 32. The minimum number of specimens and the tests to which they are to be subjected are given in Table 10. These specimens shall be prepared and tested as specified in 13.2.3.2 through 13.2.3.4 .

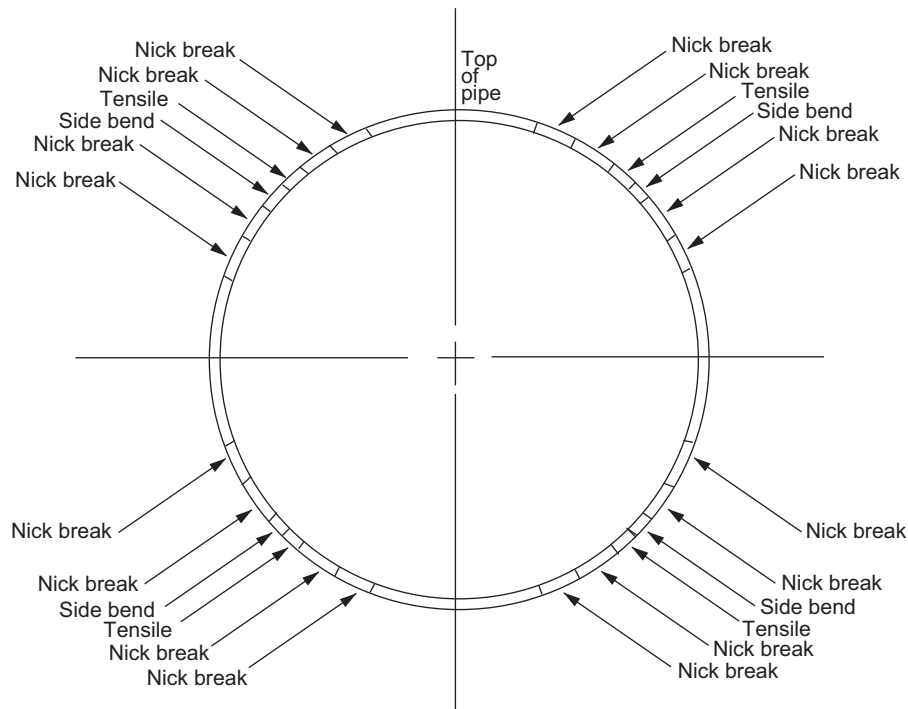

NOTE All nick break specimens shall be in accordance with Figure 26.

Figure 30—Location of Test Butt Weld Specimens for Flash Weld Procedure Qualification Test: Outside Diameter Greater Than 18 in. (457 mm) but Less Than or Equal to 24 in. (610 mm)

13.2.3.2 Tensile Strength Tests

13.2.3.2.1 Preparation

Tensile strength test specimens shall be prepared in accordance with 5.6.2.1.

13.2.3.2.2 Method

Tensile strength test specimens shall be tested in accordance with 5.6.2.2.

13.2.3.2.3 Requirements

The tensile strength of the weld, including the fusion zone of each specimen, shall be greater than or equal to the SMTS of the parent metal but need not be greater than or equal to the actual tensile strength of the material. If the specimen breaks outside the weld and fusion zone (i.e. in the parent metal) and meets the minimum tensile strength requirements of the specification, the weld shall be accepted as meeting the requirements.

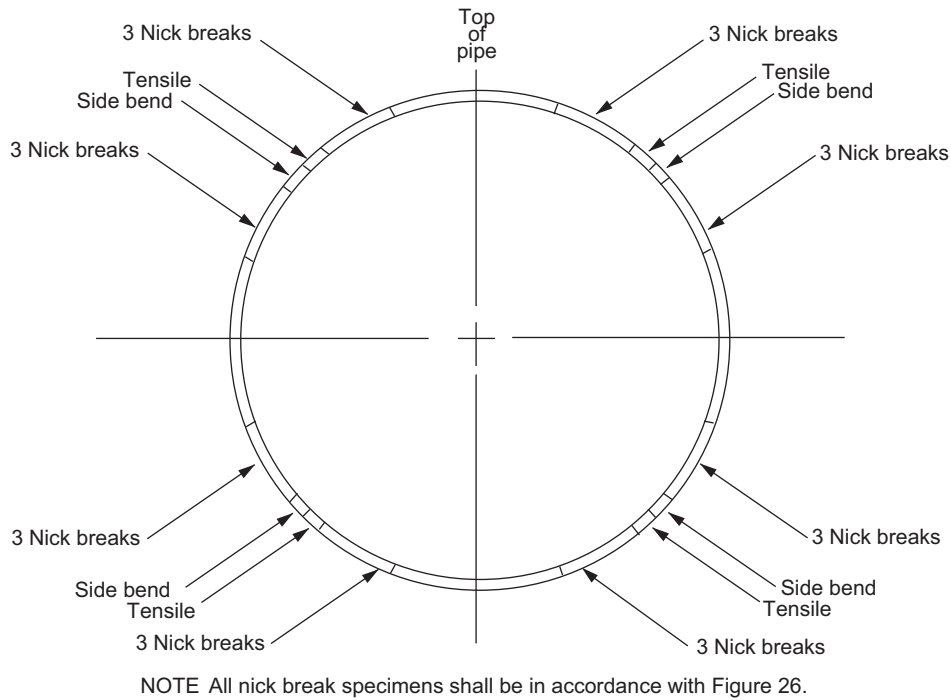

Figure 31—Location of Test Butt Weld Specimens for Flash Weld Procedure Qualification Test: Outside Diameter Greater Than 24 in. (610 mm) but Less Than or Equal to 30 in. (762 mm)

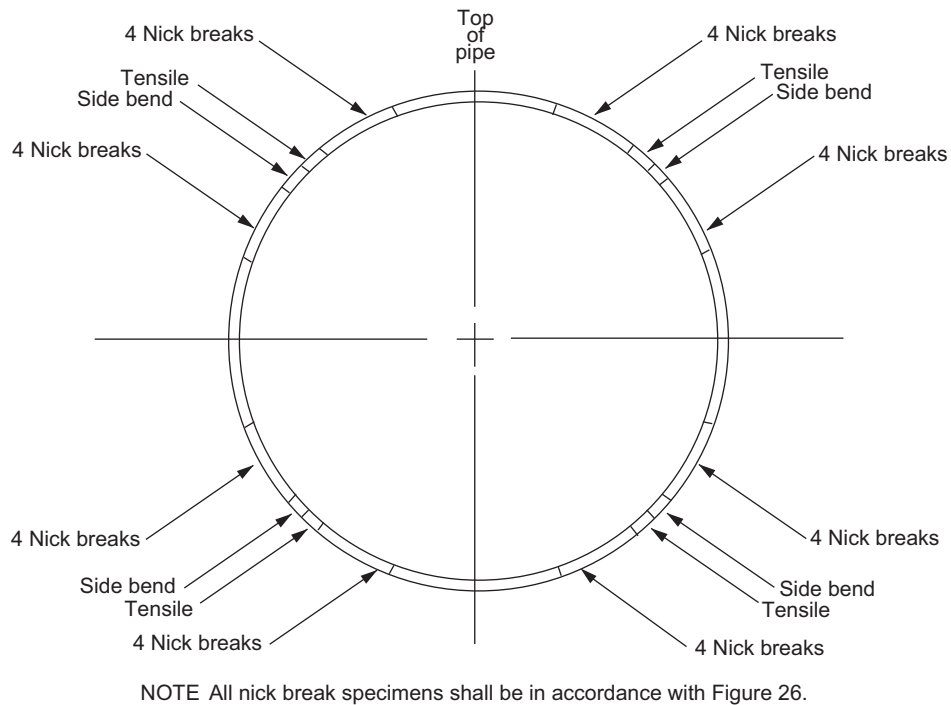

Figure 32—Location of Test Butt Weld Specimens for Flash Weld Procedure Qualification Test: Outside Diameter Greater Than 30 in. (762 mm)

Table 10—Type and Number of Test Specimens for Procedure Qualification Test (Flash Weld Only)

Outside Diameter of Pipe		Number of Specimens				
		Tensile Strength	Nick Break		Side Bend	Total
in.	mm		2 in.	Standard		
>18 to 24	>457 to 610	4	16	0	4	24
>24 to 30	>610 to 762	4	24	0	4	32
>30	>762	4	32	0	4	40

If the specimen breaks in the weld or fusion zone, the observed strength is greater than or equal to the SMYS of the parent metal, and the weld meets the requirements for soundness given in 13.2.3.3.3, the weld shall be accepted as meeting the requirements.

13.2.3.3 Nick Break Test

13.2.3.3.1 Preparation

The number of 2-in. nick break specimens required by Table 10 shall be prepared in accordance with Figure 33. The sides of the specimen shall be macroetched to locate the fusion line. The sides of the specimen shall be notched along the fusion line with a saw; each notch shall be approximately $\frac{1}{8}$ in. (3 mm) deep. In addition, the ID and OD weld reinforcement shall be notched to a depth of not more than $\frac{1}{16}$ in. (1.6 mm), measured from the weld surface. Edges of the specimen shall be smooth and parallel.

13.2.3.3.2 Method

Nick break specimens shall be tested in accordance with 5.6.3.2.

13.2.3.3.3 Requirements

The exposed surfaces of each nick break specimen shall show complete penetration and fusion. Slag inclusions shall not exceed $\frac{1}{8}$ in. (3 mm) in length or width. There shall be at least $\frac{1}{2}$ in. (13 mm) of sound weld metal between adjacent slag inclusions.

13.2.3.4 Side Bend Test

13.2.3.4.1 Preparation

Side bend specimens shall be prepared in accordance with 5.6.5.1.

13.2.3.4.2 Method

Side bend specimens shall be tested in accordance with 5.6.5.2.

13.2.3.4.3 Requirements

The requirements for the performance of side bend specimens shall be in accordance with 5.6.4.3.

13.3 Record

The details of each qualified procedure shall be recorded on a form incorporating, as a minimum, all of the items included in 13.4. This record shall show complete results of the procedure qualification test and shall be maintained as long as the procedure is in use.

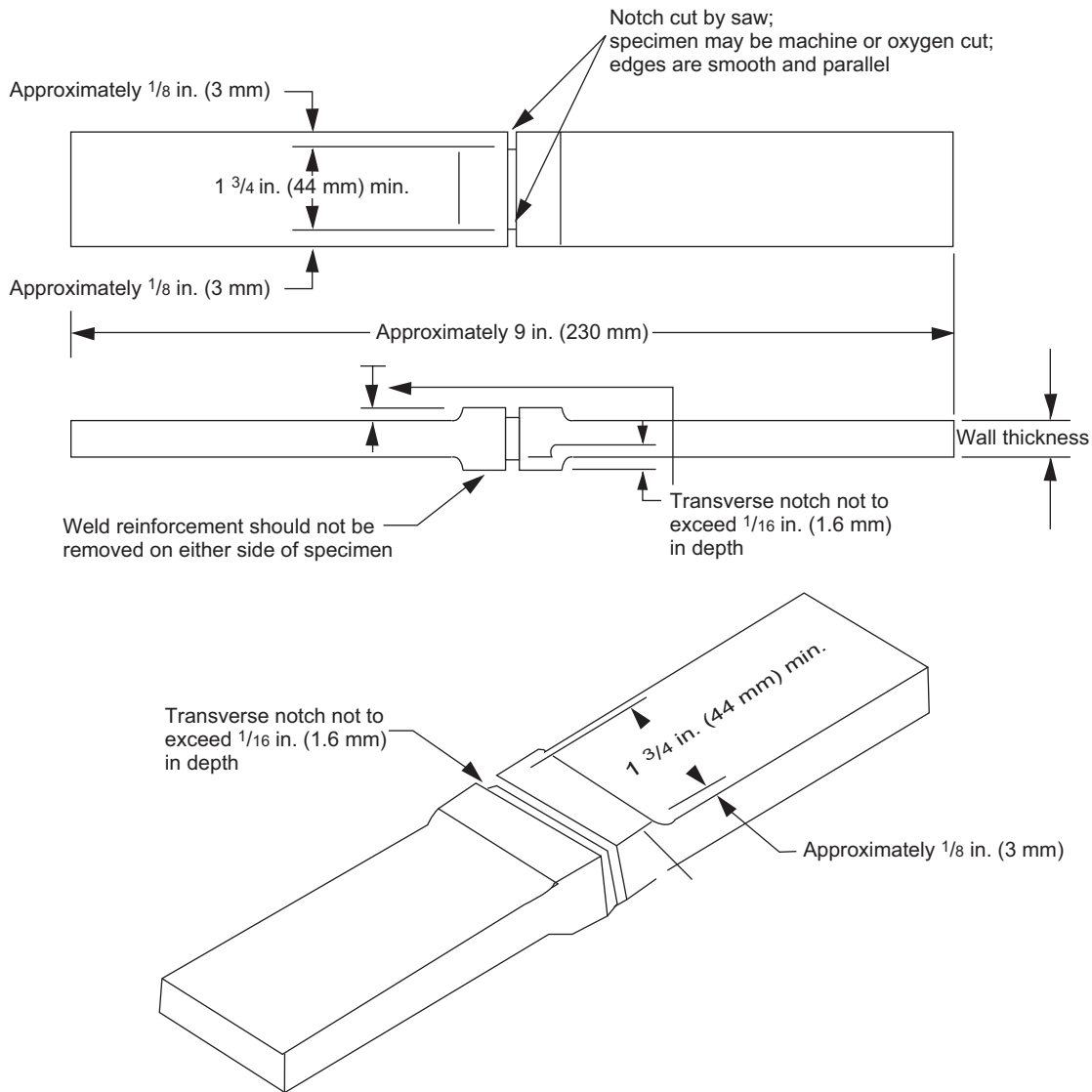

Figure 33—Two-in. Nick Break Test Specimen

13.4 Welding Procedure Specification

The welding procedure specification shall include all the information that is pertinent to setting up and maintaining the proper operation of the equipment as indicated in the following items:

- a) welding process;
- b) pipe material;
- c) pipe wall thickness and OD;
- d) pipe end preparation;

- e) preparation of the pipe, including grinding of the pipe seam weld, if any, and cleaning of the pipe ends for electrical contact;
- f) welding position;
- g) requirements for preheat treatment;
- h) requirements for cleaning and inspection of contact shoes;
- i) range of welding voltage, which shall be recorded on a strip chart;
- j) range of welding amperage, which shall be recorded on a strip chart;
- k) range of axial speed, which shall be recorded on a strip chart;
- l) time intervals in weld cycle, which shall be identified and recorded on a strip chart;
- m) range of upset stroke, which shall be recorded on a strip chart;
- n) time delay before removal of clamps;
- o) method of removing internal flash;
- p) method of removing external flash;
- q) requirements for PWHT, including heating time, maximum temperature, time of temperature, method of determining heating around circumference, and cooling rate.

13.5 Essential Variables

13.5.1 General

A welding procedure shall be reestablished as a new welding procedure specification and shall be completely requalified when any of the essential variables listed in 13.5.2 are changed. Changes other than those given in 13.5.2 may be made in the procedure without the need for requalification, provided the welding procedure specification is revised to show the changes.

13.5.2 Changes Requiring Requalification

A change in any of the factors listed in Items a) through k) below constitutes an essential variable:

- a) pipe material;
- b) specified pipe wall thickness or specified OD;
- c) pipe preparation dimensions;
- d) welding position;
- e) requirements for preheat treatment;
- f) welding voltage tolerances;
- g) welding current tolerances;

- h) axial speed tolerances;
- i) time intervals in weld cycle;
- j) upset stroke tolerances;
- k) requirements for PWHT.

13.6 Qualification of Equipment and Operators

Each welding unit and each operator shall be qualified by producing an acceptable weld using the qualified welding procedure. The completed weld shall be tested by both radiographic and mechanical test methods, as specified in 13.2. Each operator shall have received adequate training in the operation of the equipment prior to the start of welding and shall be thoroughly familiar with the equipment they operate.

13.7 Records of Qualified Operators

A record shall be made of the tests required by 13.6 and of the detailed results of each test. A form similar to that shown in Figure 2 should be used. (This form should be developed to suit the needs of the company but must be sufficiently detailed to demonstrate that the qualification test meets the requirements of this standard.) A list of qualified operators and the procedures for which they are qualified shall be maintained. An operator may be required to requalify if a question arises about their competence.

13.8 Quality Assurance of Production Welds

13.8.1 Rights of Inspection

The company shall have the right to inspect all welds by nondestructive means and by removing welds and subjecting them to metallurgical or mechanical tests or both. The frequency of such additional inspections and tests shall be as specified by the company.

13.8.2 Rejection Based on Strip Chart

During the automatic welding sequence, the operator shall monitor the electrical and mechanical procedure parameters of the welding machine on an appropriate strip chart recorder.

If any of the welding parameters deviate beyond the tolerances specified in the welding procedure specification, the weld shall be unacceptable. If the strip chart is found to be unacceptable after welding has been completed, the joint shall be rejected and removed from the line.

13.8.3 Rejection Based on NDT

Each production weld shall be inspected visually and radiographically after flash removal and PWHT are complete. Other nondestructive tests may also be required by the company. Each production weld shall meet the requirements of 13.9.

13.8.4 Rejection Based on Reinforcement

The ID weld reinforcement shall not be raised above the parent material by more than $1/16$ in. (2 mm). The OD weld reinforcement shall not be raised above the parent material by more than $1/8$ in. (3 mm).

13.8.5 Rejection Based on PWHT

As a minimum, each completed flash butt weld shall be heated after welding to a temperature above the Ac3 temperature, followed by either controlled cooling or still-air cooling. The heat treatment cycle shall be documented using a strip chart recorder, and any deviation beyond the ranges specified for heating time, maximum temperature, or cooling rate shall be cause for reheat treatment.

13.9 Acceptance Standards for NDT

13.9.1 General

The acceptance standards given in 13.9.2 are applicable to the determination of the size and type of imperfections located by radiography and other nondestructive test methods. They may also be applied to visual inspection.

13.9.2 Defects

ISIs shall be considered defects if any single ISI exceeds $\frac{1}{8}$ in. (3 mm) or if the aggregate length of ISIs in any continuous 12 in. (300 mm) length of weld exceeds $\frac{1}{2}$ in. (13 mm). In flash butt welds, cracks, IF, and porosity detected by NDT are considered defects.

13.10 Repair and Removal of Defects

13.10.1 Repairs Permitted

The following repairs are permissible.

- a) Surface defects may be removed by grinding, provided the pipe's minimum wall thickness is not violated.
- b) Defects may be removed from the weld by grinding, chipping, gouging, or a combination of these methods, followed by a weld repair in accordance with Section 10.

Repair by welding is permitted only by agreement with the company.

13.10.2 Repairs Not Permitted

Repair of porosity found in flash butt welds is not permitted; however, porosity in a repair weld deposit made with a different welding process is permitted within the limits defined in 9.3.9.2 or 9.3.9.3, whichever is applicable.

13.11 Radiographic Procedure

Radiographic testing shall be in accordance with 11.1.

Annex A (normative)

Alternative Acceptance Standards for Girth Welds

A.1 General

The acceptance standards given in Section 9 are based on empirical criteria for workmanship and place primary importance on imperfection length. Such criteria have provided an excellent record of reliability in pipeline service for many years. The use of fracture mechanics analysis and fitness-for-purpose criteria for determining acceptance criteria is an alternative method and incorporates the evaluation of both imperfection height and imperfection length. Typically, but not always, the fitness-for-purpose criteria provide more generous allowable imperfection length. Additional qualification tests, stress analysis, and inspection are required to use the fitness-for-purpose criteria. Performing analysis based on the principles of fitness-for-purpose is alternatively termed engineering critical assessment, or ECA.

The fitness-for-purpose criteria in the prior versions of this annex required a minimum crack tip opening displacement (CTOD) toughness of either 0.005 in. or 0.010 in. (0.13 mm or 0.25 mm) and were independent of any higher values of fracture toughness. Improvements in welding consumables and with more precise welding procedures, especially, with the increased use of mechanized welding devices have resulted in higher and more uniform toughness and ductility in most welds. At the same time, toughness values below 0.005 in. (0.13 mm) have been observed, particularly with more stringent notching procedures of CTOD specimens than those in the prior versions of this annex. Welds with CTOD toughness below 0.005 in. (0.13 mm) have shown to perform adequately when the acceptance criteria are properly adjusted to account for the lower toughness. The acceptance criteria are revised so that they are commensurate with the measured toughness and applied load levels.

This annex includes three options for the determination of acceptance limits of planar imperfections. In numerical order, the options are increasingly complex in application but offer wider range of applicability. Option 1 provides the simplest methodology. Option 2 allows for the full utilization of the toughness of the materials thus providing a more accurate criterion but requires more calculation. The first two options were developed with a single set of underlying procedures but are limited to applications with a low to moderate fatigue loading as described in A.2.2.1.⁷ Option 3 is provided primarily for those cases where fatigue loading exceeds the limit established for the first two options. Option 3 is not prescriptive, and its consistency could be significantly less than Options 1 and 2. Option 3 should only be exercised, when necessary, by skilled practitioners with demonstrated knowledge of fracture mechanics and pipeline load analysis. With these three options, this current revision of the annex should provide a more complete approach to determine inspection and acceptance limits for imperfections.

It is usually impractical to qualify individual pipeline welds for the alternative acceptance limits after a defect under Section 9 is detected, because destructive testing is required to establish the required mechanical properties for the welding procedure under consideration.

This annex provides procedures to determine the maximum allowable imperfection sizes. It does not prevent the use of Section 9 for determining imperfection acceptance limits for any weld. Use of this annex is completely at the company's option.

In this annex, the use of the phrase imperfection acceptance limits and other phrases containing the word imperfection is not intended to imply a defective condition or any lack of weld integrity. All welds contain certain features variously described as artifacts, imperfections, discontinuities, or flaws. These terms are widely accepted and used interchangeably. The primary purpose of this annex is to define, on the basis of a technical analysis, the effect of various types, sizes, and shapes of such anomalies on the suitability of the whole weld for a specific service.

⁷ Y.-Y. Wang and M. Liu, "A Comprehensive Update in the Evaluation of Pipeline Weld Defects," U.S. DOT Agreement No. DTRS56-03-T-0008, PRCI Contract No. PR-276-04503, draft report to DOT and PRCI, November 2004.

This use of this annex is restricted to the following conditions:

- circumferential welds between pipes of equal specified wall thickness;
- nondestructive inspection performed for essentially all welds;
- no gross weld strength undermatching, see A.3.2.1;
- maximum axial design stress no greater than the SMYS;
- maximum axial design strain no greater than 0.5 %;
- welds in pump and compressor stations, repair welds, fittings, and valves in the main line are excluded.

A.2 Stress Analysis

A.2.1 Axial Design Stress

To use this annex, a stress analysis shall be performed to determine the maximum axial design stresses to which the girth welds may be subjected to during construction and operation. The stress analysis shall include stresses during pipeline installation and stresses induced by operational and environmental conditions. Under typical onshore construction conditions, the highest axial stress may occur during the pipe lowering-in process. The lowering-in stress is predominantly controlled by the lift height of the pipe relative to the bottom of the trench. The stresses from horizontal directional drilling can be estimated from the curvature of the pipe path, pull force, and the interaction between the pipe and surrounding soil (including friction).⁸ These stresses may reach their peak values at different times. The maximum axial design stress is the maximum total axial stress at any given time during the design life of the pipeline.⁹

A.2.2 Cyclic Stress

A.2.2.1 Analysis

The cyclic stress analysis shall include the determination of the predicted fatigue spectrum to which the pipeline will be exposed over its design life. This spectrum shall include but is not limited to stresses imposed by hydrostatic testing, operation pressure, installation stresses, and where applicable, thermal, seismic, and subsidence stresses. The spectrum should consist of several cyclic axial stress levels and the number of cycles applicable to each. If the stress levels vary from cycle to cycle, a suitable counting method, such as the rainflow method, should be used to determine cyclic stress levels and cycle count.¹⁰

The fatigue spectrum severity, S^* , is computed from the following equation:

$$S^* = N_1(\Delta\sigma_1)^3 + N_2(\Delta\sigma_2)^3 + \dots + N_i(\Delta\sigma_i)^3 + \dots + N_k(\Delta\sigma_k)^3 \quad (\text{A.1})$$

where

S^* is the spectrum severity;

N_i is the number of cycles at the i th cyclic stress level;

⁸ More details of the stress analysis may be found in reference M. Liu, Y.-Y. Wang, and G. Rogers, "Stress Analysis of Pipe Lowering-in Process During Construction," Proceedings of the 7th International Pipeline Conference, Paper No. IPC2008-64630, Calgary, Alberta, Canada, September 29 to October 3, 2008.

⁹ For consistency with the computation of material's flow stress in this annex, stress-strain relations based on minimum specified values are recommended when converting axial strains to axial stresses. Using actual stress-strain relations may result in the overestimation of the applied load level, as the flow stress is computed from the minimum specified values (e.g. see A.5.1.3).

¹⁰ For an example of the use of the rainflow method, see N. E. Dowling, "Fatigue Failure Predictions for Complicated Stress-Strain Histories," *Journal of Materials*, Volume 7, Number 1, pp. 71 to 87, March 1972.

$\Delta\sigma_i$ is the i th cyclic stress range, in kips per in.² (ksi);

k is the total number of cyclic stress levels;

i is the number i th cyclic stress, from 1 to k .

If the spectrum severity is less than 5×10^6 and if the use of “steel in-air” crack growth curves, such as those defined in Table 4 of BS 7910, is appropriate, Options 1 and 2 acceptance criteria (A.5.1.3 and A.5.1.4) may be applied without any further fatigue analysis.¹¹ If the spectrum severity exceeds 5×10^6 and/or in-air crack growth curves are not applicable, Options 1 and 2 may be used with further analysis, or Option 3 procedures may be applied.¹²

A.2.2.2 Environmental Effects on Fatigue

The enlargement of weld imperfections due to fatigue is a function of stress intensity, cycles of loading, imperfection size, and the environment at the crack tip. In the absence of contaminating elements, oil and hydrocarbons are considered no worse than air. Water, brine, and aqueous solutions that contain CO₂ or H₂S may, however, increase the growth rate. It is normal for minor amounts of these components to be present in nominally noncorrosive pipelines. When the concentration of either CO₂ or H₂S exceeds typical historical levels experienced in noncorrosive pipelines, this annex shall not be used, unless evidence exists that the proposed levels do not result in acceleration of fatigue crack growth or adequate corrosion inhibition is applied. The effects of environment on fatigue crack growth external to the pipe at girth welds are normally mitigated by external coating and cathodic protection and do not limit the use of this annex.

A.2.3 Sustained-load Cracking

Certain environments may enhance imperfection growth in service at sustained load or induce brittleness in the material surrounding the imperfection to the point that an otherwise dormant imperfection becomes critical. These environments typically contain H₂S but may contain strong hydroxides, nitrates, or carbonates. When these materials are present inside the pipe, a minimum threshold stress shall be established, and this annex shall not be used if the calculated stress exceeds the threshold value. With respect to H₂S service, the definition of such service shall be that given in NACE MR0175. Although external exposure to carbonates and nitrates in the soil has been shown to produce stress corrosion cracking (SCC) in a small number of cases, the cracking is normally axial and is associated with circumferential stress rather than axial stress. However, circumferential SCC failures may occur at locations where longitudinal stresses have increased over the life of the pipeline, for example, at overbends above unstable slopes.

The frequency and severity of SCC can be mitigated by the use of proper coating and proper cathodic protection. The use of this annex is not precluded when direct exposure to the aggressive environment is prevented by a coating designed to resist the environment.

A.2.4 Dynamic Loading

The stress analysis shall include consideration of potential dynamic loading on girth welds, such as loads from closure of check valves. This annex does not apply to welds strained at a strain rate greater than 10^{-3} second (a stress rate of 30 ksi/sec for steel).

¹¹ The implied safety factor in the fatigue spectrum severity limit for Options 1 and 2 varies, depending on, for example, the pipe wall thickness and distribution of fatigue spectrum. For a wide range of onshore and offshore pipeline scenarios, the spectrum severity limit is estimated to provide a safety factor of more than 2 or 5 on cycles when the fatigue growth rates are based on mean+2 standard deviation or mean values of BS 7910 (Table 4, $R > 0.5$), respectively.

¹² Options 1 and 2 provide an adequate safety factor against fracture due to moderate cyclic loading provided aforementioned “steel-in-air” curve is applicable. In other environments, for example, when determining allowable defect sizes at the OD of an offshore pipeline with fusion-bonded epoxy field joint coating and under cathodic protection, use of the “steel-in-air” curve is not appropriate and use of Option 1 or 2 may not be sufficiently conservative. Similarly, if cyclic loading exceeds the defined spectrum severity of 5×10^6 , for example, due to cyclic stresses from offshore installation loads on a pipe lay stinger, use of Option 1 or 2 may also not be sufficiently conservative.

A.2.5 Residual Stress

The effects of welding residual stress are accounted for by specifying minimum CTOD toughness and Charpy energy and by incorporating appropriate safety factor in Options 1 and 2 procedures (A.5.1.3 and A.5.1.4). The determination of residual stress is not required under these conditions. The effects of residual stress shall be evaluated for all time-dependent failure mechanisms, such as fatigue.

A.3 Welding Procedure

A.3.1 General

The controls of the variables necessary to ensure an acceptable level of fracture toughness in a welding procedure are more stringent than those controlling welding procedures without minimum toughness requirements. An appropriate quality control program shall be established to ensure welding is performed within the parameters of the qualified welding procedure. Qualification of welding procedures to be used with this annex shall be in accordance with Section 5 or Section 12 of this standard, with the additional mechanical property testing in accordance with A.3.4.

A.3.2 Essential Variables

Any change in the essential variables specified below shall require requalification of the welding procedure.

- a) A change in the welding process, mode of arc transfer, or method of application.
- b) A change in any of the following:
 - 1) grade;
 - 2) source/mill for steel (slabs, ingots, billets, etc.);
 - 3) processing facility for plate or coil used to make pipe;
 - 4) pipe manufacturing facility;
 - 5) pipe manufacturing process, including pipe forming and heat treatment process (EW, SAWL, SAWH, seamless, expanded vs not expanded, heat treated vs not heat treated);
 - 6) chemistry outside the limits defined by the manufacturing procedure specification (MPS) according to API 5L or, alternatively, if the pipe is not manufactured to an MPS, a change in any of the following:
 - i) increase in $P_{cm} \geq 0.02$ for steels with carbon content $\leq 0.12\%$ [$P_{cm} = C + Si/30 + (Mn+Cu+Cr)/20 + Ni/60 + Mo/15 + V/10 + 5B$],
 - ii) increase in $CE \geq 0.03$ for steels with carbon content $> 0.12\%$ [$CE = C + Mn/6 + (Cu + Ni)/15 + (Cr + Mo + V)/5$],
 - iii) increase in $C \geq 0.02\%$.

Chemistry compositions requirements shall be based on heat analysis results.

- c) A major change in joint design (e.g. from U groove to V groove). Minor changes in the angle of bevel or the land of the welding groove that do not yield a change in the range of qualified heat input are not essential variables.
- d) A change in position from roll to fixed, or vice versa, or from vertical to horizontal or vice versa.

- e) A change in the specified qualified wall thickness of more than ± 0.125 in.
- f) A change in the size, type, heat/lot number, or manufacturer of the filler metal and flux, even within an AWS classification.

Qualification of a new heat/lot of the filler metal may be done with a single nominal weld of the same welding procedure that is tested for weld tensile (see A.3.4.1), weld Charpy (see A.3.4.2), and weld CTOD (see A.3.4.3).

The following lot definitions within AWS A5.01 are acceptable: C2, C3, C4, C5, S2, S3, S4, T2, T3, and T4. S1 lot definitions are acceptable when the conditions of the lot definition are agreed upon between supplier and purchaser.

- 1) Filler metals identified by heat number shall be produced from one heat. For filler metals identified by heat number, a change of heat number will require requalification.
- 2) Filler metals identified by lot number shall be made from material identified either by heat number or by controlled chemical composition that are defined in AWS A5.01, Sections 4.2, 4.3, 4.4, and 4.5. For solid wire and metal-cored wires, the allowed controlled composition variation in each element about its targeted mean value is shown in Table A.1.

Table A.1—Allowed Range of Variation from the Targeted Mean Values for a Lot Defined by Controlled Chemical Composition

Alloying Element	Solid Wire Composition	Metal-cored Electrode Weld Deposit
%C	± 0.02	± 0.02
%Mn	± 0.10	± 0.15
%Si	± 0.10	± 0.10
%Ni	± 0.10	± 0.10
%Cr	± 0.05	± 0.05
%Mo	± 0.05	± 0.05
%Ti	± 0.01	± 0.02
%V	± 0.02	± 0.02
%Nb	± 0.01	± 0.01
%Cu	± 0.05	± 0.05
%P	± 0.005	± 0.005
%S	± 0.005	± 0.005
%B	± 0.001	± 0.002

- g) An increase in the time between the completion of the root bead and the start of the second bead.
- h) A change in direction (e.g. from vertical downhill to vertical uphill or vice versa).
- i) A change from one shielding gas to another or from one mixture of gases to a different mixture.
- j) A change in the nominal qualified flow rate of shielding gas of more than ± 10 %.
- k) A change in the shielding flux, including a change in manufacturer within an AWS classification.

- l) A change in the type of current (AC or DC) or polarity.
- m) A change in the requirements for preheat temperature.
- n) A change in the interpass temperature ¹³, if the interpass temperature is lower than the minimum interpass temperature recorded during the procedure qualification test or if the interpass temperature is 45 °F (25 °C) higher than the maximum interpass temperature recorded during the procedure qualification test.
- o) A change in the requirements for PWHT or addition or deletion of a requirement for PWHT.
- p) A change in the specified pipe OD more than $-0.25D$ or $+0.5D$, where D is the pipe OD of procedure qualification welds.
- q) A change of more than $\pm 10\%$ from the nominal heat input range recorded for each weld pass during the procedure qualification.

NOTE The heat input may be calculated from the following equation:

$$J = 60VA/S \quad (A.2)$$

where

J is the heat input (joules per in.);

V is the welding arc voltage (volt);

A is the welding current (amp);

S is the welding arc speed (in. per minute).

A.3.3 Qualification of Multiple Pipe Sources

For low-dilution welding processes, such as mechanized gas metal arc welding, the qualification of a common weld procedure for multiple pipe materials as defined by A.3.2 b) may be achieved by ensuring:

- a) each material HAZ is CTOD tested per A.3.4.3.3,
- b) each material HAZ is CVN tested per A.3.4.2, and
- c) cross-weld tensile testing is performed on all test weld combinations used in Items a) or b).

It is not necessary to test welds made with all possible combinations of pipe material.

A.3.4 Mechanical Property Testing

A.3.4.1 Weld Tensile Properties

A.3.4.1.1 Specimen Preparation and Testing

The test specimens are of rectangular cross section with reduced width at the midlength. The specimens shall be prepared in accordance with the requirements of Figure A.1. The weld reinforcement shall be removed. The ends of the specimens shall be sufficient for the grips.

¹³ The temperature at a location near the start position of the welding arc(s) recorded immediately before initiating consecutive pass or passes (multi-arc processes).

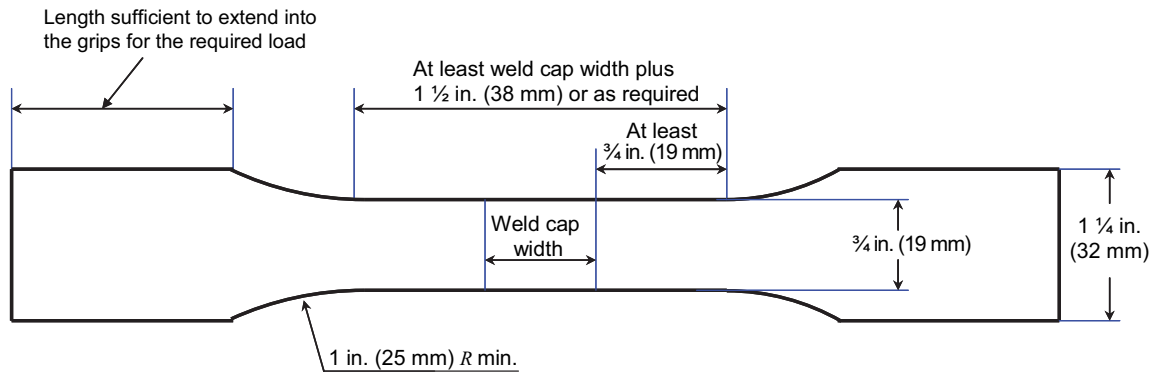

Figure A.1—Top View (Width in Circumferential Direction) of the Tensile Test Specimen

A.3.4.1.2 Requirements

The requirements for the weld based on the mechanical property test results are as follows:

- a) If the specimen breaks at a strength equal to or greater than the SMTS of the pipe, the result is acceptable and no further testing is required. Although tensile specimen failure in the weld is acceptable, provided the strength requirement is met, gross weld strength undermatching should be avoided.¹⁴
- b) If the specimen breaks in the weld or HAZ at a strength below the SMTS of the pipe material, the weld shall be rejected.
- c) If a specimen breaks outside the weld or HAZ at a tensile strength less than 100 %, but not less than (lower than) 95 % of the SMTS of the pipe material, then two additional specimens may be tested. Both retest specimens shall meet the SMTS of the pipe material. If either retest specimen fails to meet the minimum tensile strength requirement, no retesting is permitted.
- d) Any specimen that breaks outside the weld or HAZ at a tensile strength less than (lower than) 95 % of the SMTS of the pipe material shall be rejected and no further retesting is permitted.

A.3.4.2 Charpy Impact Energy

A.3.4.2.1 Specimen Preparation

Charpy V-notch impact test specimens shall be prepared with their lengths parallel to the pipe axis. The largest size specimens permitted by the pipe wall thickness should be used. The thickness of subsized specimens should have at least 80 % of the wall thickness. Six specimens shall be removed from each of the following positions: 12, 6, and 3 or 9 o'clock, for a total of 18 specimens. For each of these positions, three specimens shall have the V-notch placed in the weld centerline; and the other three shall have the V-notch placed in the HAZ as shown in Figure A.2.

A.3.4.2.2 Testing

At least nine valid specimens for each notch location (weld metal or HAZ) shall be tested at or below the minimum design temperature in accordance with the requirements of ASTM E23.

¹⁴ The company is cautioned to consider weld undermatching issues as it relates to pipeline bending or other longitudinal tensile loads. An example of assessing weld strength undermatching is given in Y.-Y. Wang, M. Liu, D. Horsley, and G. Bauman, "A Tiered Approach to Girth Weld Defect Acceptance Criteria for Stress-based Design of Pipelines," 6th International Pipeline Conference, Paper No. IPC2006-10491, Calgary, Alberta, Canada, September 25 to 29, 2006.

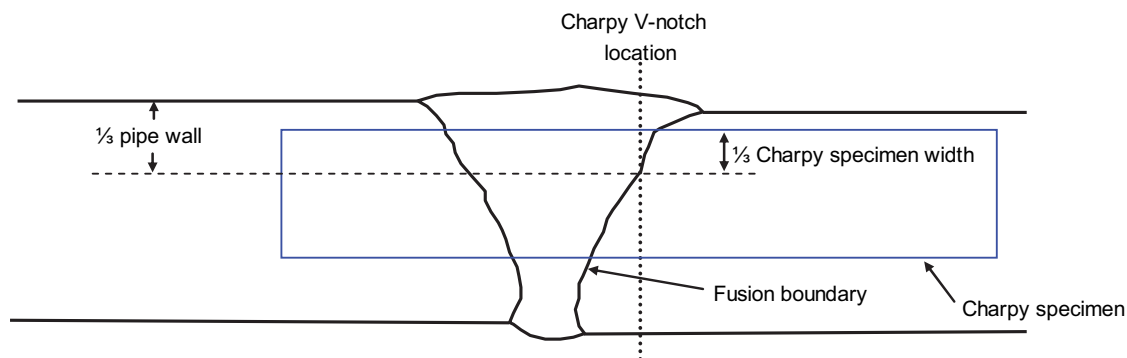

Figure A.2—Charpy Specimen and V-notch Location for the HAZ Impact Testing

A.3.4.2.3 Requirements

The impact energy for each notch location (weld metal or HAZ) is acceptable when the following criteria are met:

- a) the average absorbed energy for each set of three specimens equals or exceeds 30 ft-lb (40 J);
- b) the minimum individual absorbed energy for each set of three specimens equals or exceeds 22 ft-lb (30 J);
- c) when subsized Charpy specimens are used, the energy requirements, without correction or conversion, as stated in Items a) and b) above shall apply.

A.3.4.2.4 Retesting

Retesting is permitted when no more than one specimen in each group of nine specimens (weld metal or HAZ) generates an absorbed energy less than 22 ft-lb (30 J), but the average absorbed energy from the set of three specimens that contains the low individual value exceeds 30 ft-lb (40 J). The retest requirements are as follows:

- a) the three retest specimens shall be extracted from a location as close as possible to the location of the specimen that generated the low result,
- b) the absorbed energy of all three retest specimens shall meet or exceed 30 ft-lb (40 J).

If the above retest criteria are satisfied, the Charpy results are acceptable. If the above criteria are not satisfied, no further retesting is permitted and the weld is rejected.

A.3.4.3 Fracture Toughness Testing

A.3.4.3.1 General

To use the alternative acceptance criteria, the fracture toughness of the weld shall be determined by testing in accordance with BS EN ISO 15653, as supplemented by this annex.

A.3.4.3.2 Specimen Preparation

The preferred test piece ($B \times 2B$) shall be used. As shown in Figure A.3, the specimen should be oriented so that its length is parallel to the pipe axis and its width is in the circumferential direction; thus, the crack tip line is oriented in the through-thickness direction. The specimen thickness (see Figure A.4) should be equal to the pipe thickness less the minimum amount of milling and grinding necessary to produce a specimen with the prescribed rectangular cross section and surface finish from a curved pipe segment. The weld reinforcement shall be removed. The specimen

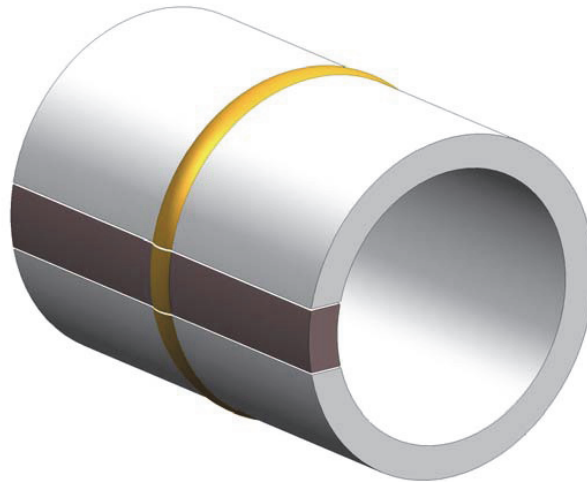

Figure A.3—Orientation of CTOD Test Specimen

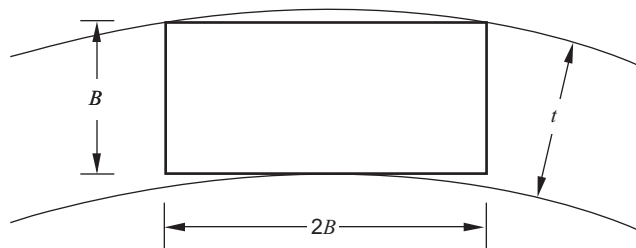

Figure A.4—Machining Objective for CTOD Test Specimen with Respect to Pipe Wall

should be etched after initial preparation to reveal the weld deposit and the geometry of the HAZ. For weld metal tests, the notch and fatigue crack tip should be located at the center of the weld and completely in weld metal (see Figure A.5).

For the HAZ tests, the fatigue precracks shall be aimed to intersect the largest unrefined coarse grain HAZ regions within the central 70 % of the specimen thickness (see Figure A.6). Each of the three HAZ specimens should be aimed at different coarse grained regions within the central 70 %. If there are fewer than three such regions in the central 70 %, then multiple specimens may be aimed at the same region. Multiple specimen sampling of the cap pass coarse grain HAZ should be avoided. No more than one specimen should be devoted to the cap pass HAZ. To identify coarse grain HAZ regions, it may be useful to conduct a microhardness survey to locate the coarsest HAZ regions that have undergone the least amount of tempering by subsequent weld passes.

A.3.4.3.3 CTOD Toughness Testing

For each welding procedure, both the weld metal and the HAZ shall be tested. Each set of tests (of weld metal or HAZ) shall consist of at least three valid specimen tests performed at or below the minimum design temperature. The three specimens shall consist of one each from the nominal 12, 3 or 9, and 6 o'clock positions on the test weld and should be permanently marked to identify the original position.

After testing, particular attention should be given to the qualification criteria in 12.4 (particularly 12.4.3) of BS EN ISO 15653; these criteria deal with the geometry of the fatigue crack front. For this annex, the appropriate value of CTOD shall be δ_c , δ_i , or δ_m . [These are mutually-exclusive terms defined in BS EN ISO 15653 that describe the three possible and mutually-exclusive outcomes of the test. The value of δ_i (CTOD at initiation of stable crack growth) has

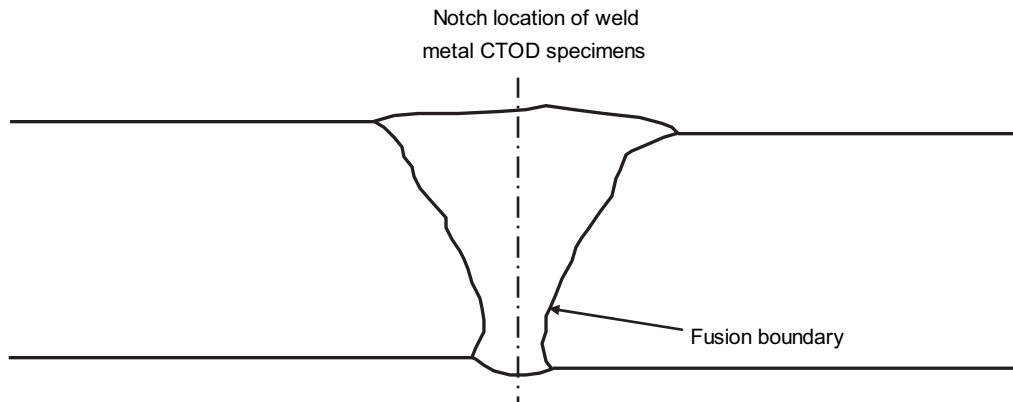

Figure A.5—Location of Notch for Weld Metal Specimen

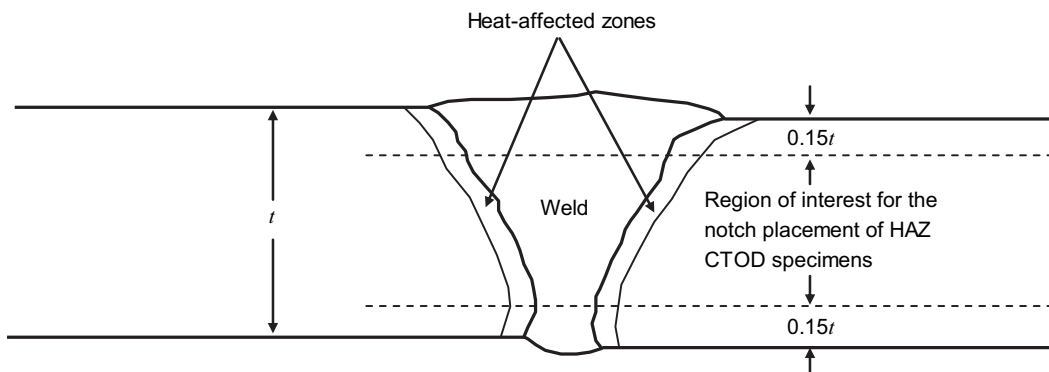

Figure A.6—Location of Notch for Heat-affected Zone Specimen

no significance with regard to this annex and need not be measured.] When δ_m applies, care should be taken to measure from the point of first attainment of maximum load. “Pop in cracking” must be considered the controlling event if any load drop occurs. The test report shall include all items specified in Section 13 of BS EN ISO 15653. Particular attention should be given to reporting the position of the test specimen in the qualification weld and to distinguishing whether the reported CTOD value represents δ_c , δ_u , or δ_m . The test report shall also include a legible copy of the load-displacement record and a record of the appearance of the fracture surfaces; the latter requirement can be satisfied by a clear photograph of one or both fracture surfaces or by retaining one or both fracture surfaces (properly preserved and identified) for direct observation. Unless otherwise specified by the company, the notch location shall be defined as weld positional per BS EN ISO 15653, that is, no postweld metallography is required.

A.3.4.3.4 Retesting

Retesting is permitted on a one-to-one basis only when any of the following conditions exist:

- specimens are incorrectly machined,
- the fatigue crack front fails to meet the straightness requirements,
- substantial weld imperfections adjacent to the crack front are observed upon the fracture of the specimen.

A.3.4.3.5 Requirements

The minimum CTOD value of all six specimens shall be greater than 0.002 in. (0.05 mm) to use this annex.

A.3.4.4 [section deleted]

A.4 Qualification of Welders

Welders shall be qualified in accordance with Section 6. For mechanized welding, each operator shall be qualified in accordance with 12.6.

A.5 Inspection and Acceptable Limits

A.5.1 Planar Imperfections

A.5.1.1 General

The length and height of an imperfection, and its depth below the surface, shall be established by appropriate nondestructive inspection techniques or otherwise justified before a decision to accept or reject can be made. Conventional radiography, as described in 11.1, is adequate for measuring imperfection length but is insufficient for determining height, particularly for planar imperfections such as cracks, lack of fusion, undercutting, and some types of lack of penetration. The use of ultrasonic techniques, radiographic techniques that employ densitometers or comparative visual reference standards, acoustic imaging, inherent imperfection-size limitations due to weld-pass geometry, or any other technique for determining imperfection height is acceptable, provided the technique's accuracy has been established (e.g. see 11.4.4) and any potential inaccuracy is included in the measurement; that is, the determination of imperfection height shall be conservative. The use of conventional radiography (see 11.1) to identify imperfections that require height measurement by other means is acceptable.

A.5.1.2 Structure of the Procedures to Determine the Maximum Acceptable Imperfection Size

The procedures to determine the maximum acceptable planar imperfection size are given in three options. Option 1 is a simplified approach in graphical format. It relies on theoretically sound and experimentally validated plastic collapse criteria, and has been modified by the Option 2 approach when appropriate. Option 2 is in the form of a failure assessment diagram, or FAD. The FAD format allows the simultaneous consideration of brittle fracture, plastic collapse, and the interaction between those two failure modes (elastic-plastic fracture). Options 1 and 2 are limited to pipelines with limited fatigue loads as specified in A.2.2. Option 3 permits the use of validated fitness-for-purpose procedures when the cyclic loading exceeds the spectrum requirements of Options 1 and 2.

The Option 1 procedures are limited to CTOD toughness equal or greater than 0.004 in. (0.10 mm). The Options 2 and 3 procedures may be applied at any CTOD toughness level greater than the minimum required value of 0.002 in. (0.05 mm).

The basis of the Options 1 and 2 procedures places no limit on pipe diameter or diameter to wall thickness ratio (D/t ratio). Theoretical validation has shown that the procedures are valid for $D/t \geq 10$.

Line pipes with ultrahigh Y/T ratio ($Y/T > 0.95$) are often associated with low uniform strain (engineering strain at ultimate tensile stress) and low ductility. Additional testing and validation may be necessary to use the alternative acceptance criteria in this annex.

A.5.1.3 Determination of Acceptable Imperfection Size by Option 1

A.5.1.3.1 General

Two sets of acceptance criteria are given, depending on the CTOD toughness value.

When the CTOD toughness is equal to or greater than 0.010 in. (0.25 mm), the maximum acceptable imperfection size is given in Figure A.7 at various load levels (P_T). If the load level is not given in Figure A.7, the maximum

acceptable imperfection size can be obtained by interpolating the adjacent curves or by taking the value of the next higher load level.

When the CTOD toughness is equal to or greater than 0.004 in. (0.10 mm) and less than 0.010 in. (0.25 mm), the maximum acceptable imperfection size is given in Figure A.8.

The acceptable imperfection size may be more limiting than that from the Option 2 procedure as the limits in Figure A.7 and Figure A.8 were calibrated to a CTOD toughness of 0.010 in. (0.25 mm) and 0.004 in. (0.10 mm), respectively.

The total imperfection length shall be no greater than 12.5 % of the pipe circumference. The maximum imperfection height shall be no greater than 50 % of the pipe wall thickness.

The allowable height of the buried imperfections is treated the same as the allowable height of the surface-breaking imperfections.

The built-in safety factor in the acceptable imperfection size can accommodate certain amount of undersizing of imperfection height without negatively impacting weld integrity. The assumed height uncertainty is the lesser of 0.060 in. (1.5 mm) and 8 % of pipe wall thickness. No reduction in allowable imperfection size is necessary if the allowance for inspection (alternatively termed inspection error) is better than the assumed height uncertainty.

The allowable imperfection height shall be reduced by the difference between the allowance for inspection and the assumed height uncertainty if the above condition cannot be met.¹⁵

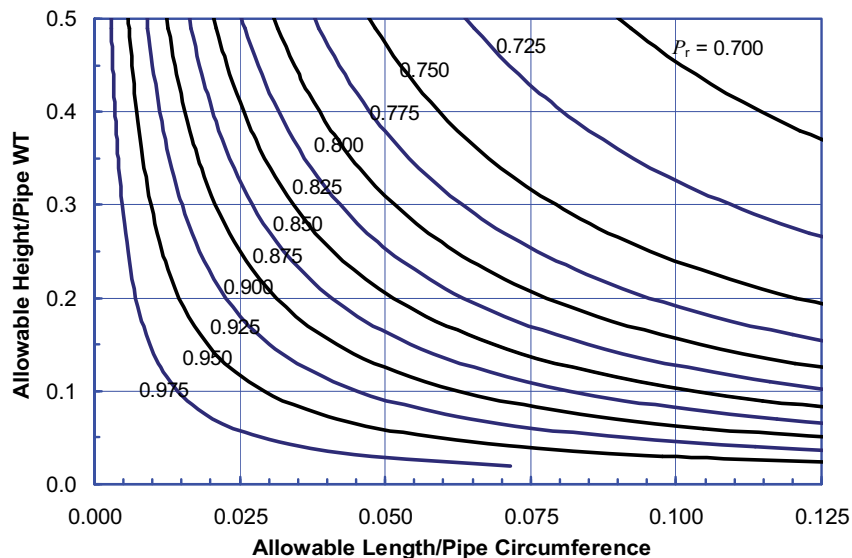

Figure A.7—Option 1 Imperfection Limits for CTOD \geq 0.010 in. (0.25 mm)

¹⁵ See example problem in A.5.1.3.3.

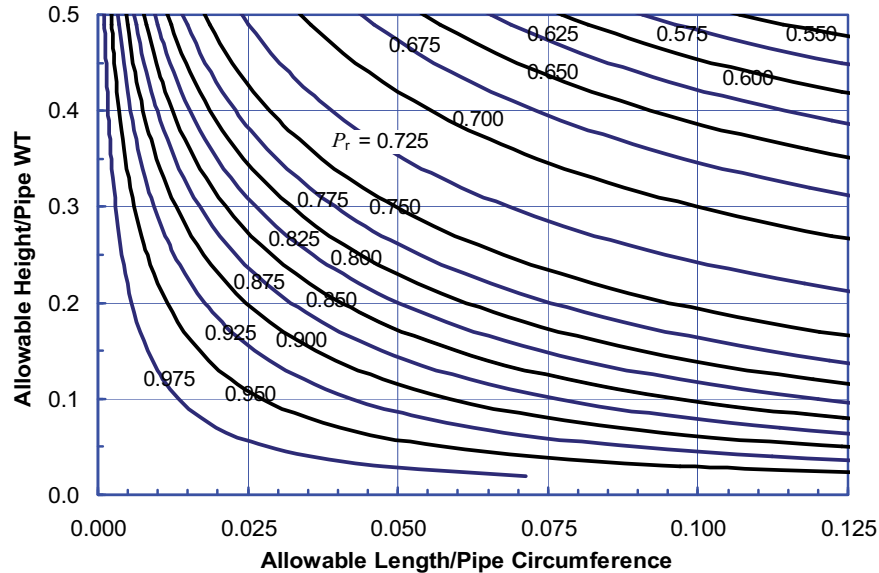

Figure A.8—Option 1 Imperfection Limits for 0.004 in. (0.10 mm) ≤ CTOD < 0.010 in. (0.25 mm)

A.5.1.3.2 Computation of the Load Level P_r

It is necessary to determine material's flow stress in order to obtain the load level P_r . The flow stress is the averaged value of the SMYS and SMTS. Alternatively the flow stress of API 5L Grade X52 to X80 may be conservatively estimated as:

$$\sigma_f = \sigma_y \left[1 + \left(\frac{21.75}{\sigma_y} \right)^{2.30} \right] \quad (\text{A.3})$$

where the pipe grade, σ_y , is in the unit of ksi. The load level, P_r , is given as:

$$P_r = \frac{\sigma_a}{\sigma_f} \quad (\text{A.4})$$

A.5.1.3.3 Example of Option 1 Application

The following is an example for performing an ECA with the Option 1 methodology. A 24 in. OD pipeline with a specified wall thickness (WT) of 0.50 in. with the grade of API 5L X70 is considered. After reviewing A.1 and A.2 of this annex and consulting with the project's engineer (as required), it is understood that the maximum axial design stress is 61.5 ksi. Weld test data conducted per the requirements of the annex indicate that the minimum CTOD value is 0.011 in. These parameters are summarized as follows:

Pipe OD:	24 in.
Pipe WT	0.500 in.
SMYS:	70 ksi
SMTS:	82 ksi
CTOD:	0.011 in.
σ_a :	61.5 ksi
Allowance for inspection:	0.050 in.

The following steps detail the ECA computation.

Step 1) Determine Flow Stress

Determine the flow stress with Equation (A.3) by substituting the 70 ksi for σ_y :

$$\sigma_f = 70 \left[1 + \left(\frac{21.75}{70} \right)^{2.30} \right] = 74.76$$

Note that for this example the flow stress can alternatively be determined as the averaged value of SMYS and SMTS, or in this case 76 ksi, a value very close to the value derived using Equation (A.3).

Step 2) Determine Applied Load Level

The load level P_r is now calculated by inserting the aforementioned values for σ_a and σ_f :

$$P_r = \frac{\sigma_a}{\sigma_f} = \frac{61.5}{74.76} = 0.823$$

Step 3) Determine Initial Allowable Imperfection Size

Figure A.7 is utilized for determining the initial allowable imperfection size (CTOD ≥ 0.010 in. or 0.25 mm). The curve of $P_r = 0.825$ in the figure is now used for the interpolations. The allowable imperfection size is tabulated in Table A.2 and shown in Figure A.9.

The allowable height quantities, shown in the second column of Table A.2, are derived by multiplying the allowable height/pipe wall thickness value by the WT that in this example is 0.500 in. Similarly, the allowable length is calculated by multiplying the allowable length/pipe circumference quantity by the pipe circumference ($\pi \times OD$) or 3.14×24 in.

Table A.2—Initial Allowable Imperfection Size for $P_r = 0.825$

Allowable Height/Pipe Wall Thickness	Allowable Height in.	Allowable Length/Pipe Circumference	Allowable Length in.
0.5	0.25	0.025	1.9
0.4	0.2	0.032	2.4
0.3	0.15	0.042	3.2
0.2	0.1	0.063	4.8
0.1	0.05	0.128	9.7

Step 4) Determine Height Adjustment

Assumed height uncertainty = lesser of 8 % WT and 0.060 in. = 0.040 in. (1.02 mm).

Allowance for inspection (i.e. inspection error) = 0.050 in. (1.27 mm).

Imperfect height adjustment = allowance for inspection – assumed height uncertainty

$$= 0.050 - 0.040$$

$$= 0.010 \text{ in. (0.25 mm).}$$

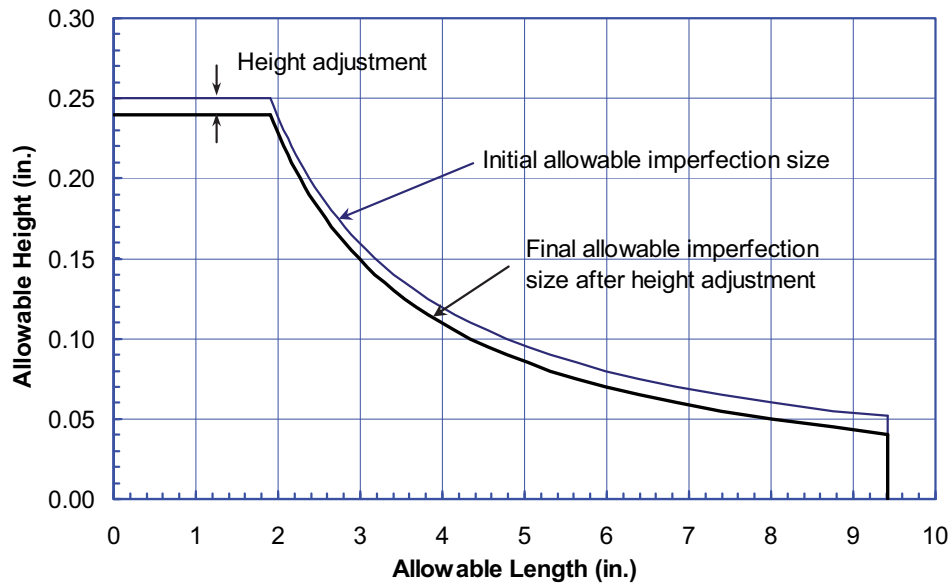

Figure A.9—Allowable Imperfection Size Curves Before and After Height Adjustment

Step 5) Produce Final Acceptance Table

The results of the ECA should be tabulated in a user-friendly format. Table A.3 suggests an operator-friendly format for this ECA example. However, a project with a heavier wall thickness may have more rows in a similar table.¹⁶

Table A.3—Example Acceptance Table

Allowable Imperfection Height in.	Allowable Imperfection Length in.
0 to 0.05	8.0
0.05 to 0.15	3.0
0.15 to 0.24	1.9
>0.24	0.0

A.5.1.4 Determination of Acceptable Imperfection Size by Option 2

A.5.1.4.1 Background

The underlining Option 2 procedure is the FAD. There are three key components in the assessment in FAD format, see Figure A.10:

- 1) failure assessment curve (FAC);
- 2) stress or load ratio, S_r or L_r ; and
- 3) toughness ratio, K_r .

The FAC is a locus that defines the critical states in terms of the stress and toughness ratios. The stress ratio defines the likelihood of plastic collapse. The toughness ratio is the ratio of applied crack driving force over the material's fracture toughness. It defines the likelihood of brittle fracture.

¹⁶ Further adjustments may be desirable, see Step 8) of A.5.1.4.2.

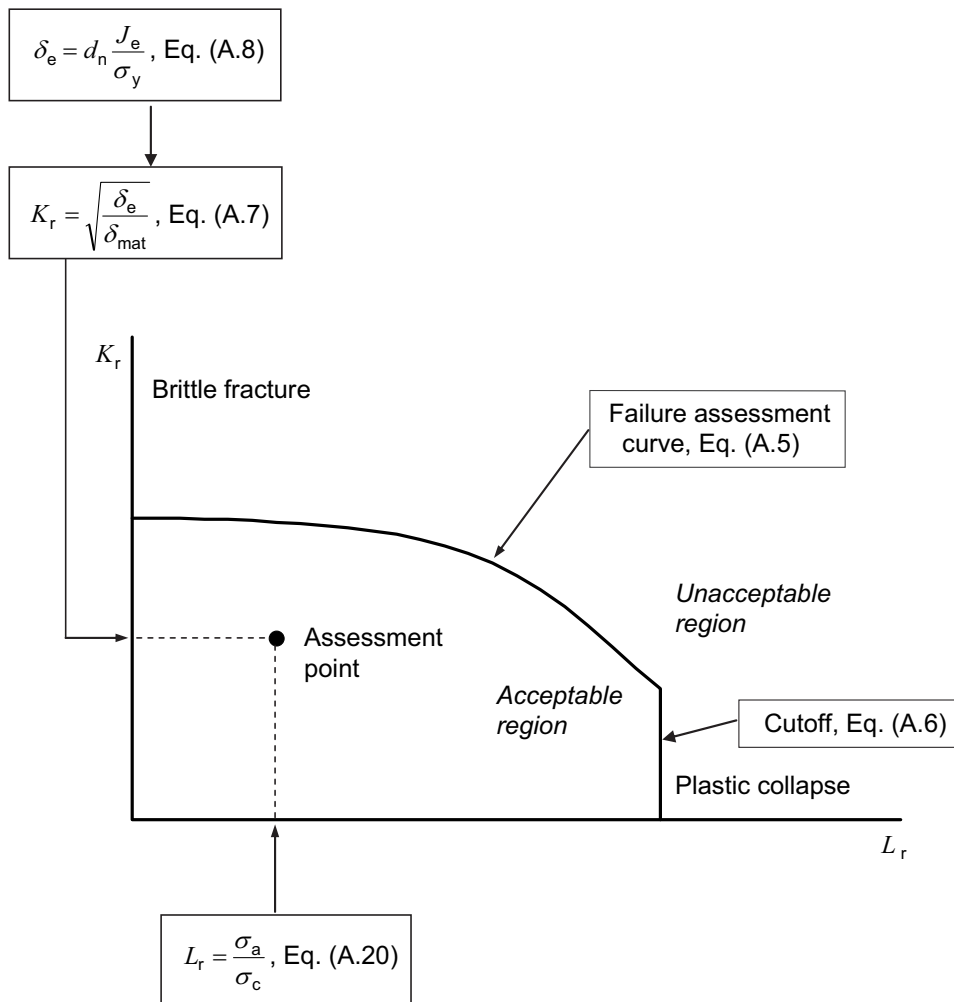

Figure A.10—Schematic Overview of the Option 2 Procedure

The FAD approach is computationally complex. Proficiency and understanding of fracture mechanics is necessary to ensure the procedure is applied correctly. A validated computer program should greatly simplify the computation.

A.5.1.4.2 Determination of Critical Imperfection Size

The critical imperfection size can be computed iteratively using equations provided in A.5.1.4.3. The following steps may be followed.

- Step 1) Select an imperfection size as a start point. A reasonable start point is an imperfection with the maximum allowed height, $\eta = 0.5$, and a small imperfection length that represents the smallest imperfection length that the selected inspection methods can confidently detect.
- Step 2) Determine the assessment point in the FAD format in accordance with A.5.1.4.3.
- Step 3) If the assessment point falls inside the safe region, increase the imperfection length and repeat Step 2).
- Step 4) If the assessment point falls outside the safe region, decrease the imperfection length and repeat Step 2).

Step 5) If the assessment point falls on the FAC:

- a) this represents a critical state with the combination of load, material property, and imperfection size. Make a note of the imperfection height and length;
- b) reduce the imperfection height by a small increment, say $\Delta h = 0.05$. Start from the imperfection length determined in Item a) and repeat Step 2).

Step 6) Make a table of critical imperfection height and length.

Step 7) Apply a safety factor of 1.5 on the imperfection length to produce a draft table of the allowable imperfection height versus imperfection length.

Step 8) Make necessary adjustment to the draft table to ensure detectability of the selected inspection methods¹⁷ and sound welding practice.¹⁸ Produce the final table of the allowable imperfection height versus imperfection length.

The total imperfection length shall be no greater than 12.5 % of the pipe circumference. The maximum imperfection height shall be no greater than 50 % of the pipe wall thickness.

The allowable height of the buried imperfections is treated the same as the allowable height of the surface-breaking imperfections.

The built-in safety factor in the acceptable imperfection size can accommodate certain amount of undersizing of imperfection height without negatively impacting weld integrity. The assumed height uncertainty is the lesser of 0.060 in. (1.5 mm) and 8 % of pipe wall thickness. No reduction in allowable imperfection size is necessary if the allowance for inspection is better than the assumed height uncertainty.

The allowable imperfection height shall be reduced by the difference between the allowance for inspection and the assumed height uncertainty if the above condition cannot be met.

A.5.1.4.3 Determination of the Key Components in the FAD Procedure

Failure Assessment Curve (FAC)

The FAC is given as:

$$K_r = f(L_r) = (1 - 0.14L_r^2)[0.3 + 0.7\exp(-0.65L_r^6)] \quad (\text{A.5})$$

The cut-off of the FAC on the L_r axis is at:

$$L_r^{\text{cutoff}} = \sigma_f / \sigma_y \quad (\text{A.6})$$

where the flow stress σ_f is the averaged value of SMYS and SMTS, or alternatively determined by Equation (A.3).

¹⁷ It is necessary to ensure that the smallest imperfection height and length could be reliably detected by the selected inspection method.

¹⁸ For thick-walled pipes, the maximum allowable height of the 50 % wall thickness could be a large value. The maximum allowable height may be reduced if such a large value is judged unnecessary by sound welding practice.

Assessment Point, Toughness Ratio K_r

The toughness ratio K_r is given as:

$$K_r = \sqrt{\frac{\delta_e}{\delta_{mat}}} \quad (\text{A.7})$$

where δ_{mat} is the CTOD toughness of the material. The elastic component of the CTOD driving force, δ_e , may be computed as:

$$\delta_e = d_n \frac{J_e}{\sigma_y} \quad (\text{A.8})$$

The J to CTOD conversion factor, d_n , is estimated as:

$$d_n = 3.69 \left(\frac{1}{n}\right)^2 - 3.19 \left(\frac{1}{n}\right) + 0.882 \quad (\text{A.9})$$

where n is the strain hardening exponent in the following stress (σ) strain (ε) relation:

$$\varepsilon = \frac{\sigma}{E} + \left(0.005 - \frac{\sigma_y}{E}\right) \left(\frac{\sigma}{\sigma_y}\right)^n \quad (\text{A.10})$$

where E is Young's modulus.

The strain hardening exponent may be estimated from Y/T ratio:

$$n = \frac{\ln(\varepsilon_t/0.005)}{\ln\{1/(Y/T)\}} \quad (\text{A.11})$$

For ferritic material of API 5L Grades X52 to X80, the Y/T ratio may be estimated as:

$$Y/T = \frac{1}{1 + 2 \left(\frac{21.75}{\sigma_y}\right)^{2.30}} \quad (\text{A.12})$$

and the uniform strain is estimated as:

$$\varepsilon_t = -0.00175\sigma_y + 0.22 \quad (\text{A.13})$$

The pipe grade, σ_y , is in the unit of ksi in Equation (A.11), Equation (A.12), and Equation (A.13).

The elastic J integral is given as:

$$J_e = \frac{K_1^2}{E/(1-\nu^2)} \quad \text{and} \quad (\text{A.14})$$

$$K_1 = \sigma_a \sqrt{\pi a} F_b \quad (\text{A.15})$$

The parameter F_b is a function of pipe diameter ratio, α , and relative imperfection length, β , and relative imperfection height η .

$$F_b(\alpha, \beta, \eta) = \begin{cases} F_{b0}(\alpha, \beta, \eta) & \eta \geq 0.1 \text{ and } \beta \leq \frac{80\eta}{\pi\alpha} \\ F_{b0}\left(\alpha, \beta = \frac{80\eta}{\pi\alpha}, \eta\right) & \eta \geq 0.1 \text{ and } \beta > \frac{80\eta}{\pi\alpha} \\ F_{b0}\left(\alpha, \beta = \frac{800.1}{\pi\alpha}, 0.1\right) & \eta < 0.1 \end{cases} \quad (\text{A.16})$$

where

$$F_{b0}(\alpha, \beta, \eta) = \left(1.09 + 2.31 \alpha^{0.791} \beta^{0.906} \eta^{0.983} + \frac{m_1}{\alpha\beta} + \alpha^{0.806} \beta m_2\right) \quad (\text{A.17})$$

$$m_1 = -0.00985 - 0.163 \eta - 0.345 \eta^2 \quad (\text{A.18})$$

$$m_2 = -0.00416 - 2.18 \eta + 0.155 \eta^2 \quad (\text{A.19})$$

Assessment Point, Stress Ratio L_r

The stress ratio L_r is given as:

$$L_r = \frac{\sigma_a}{\sigma_c} \quad (\text{A.20})$$

The plastic collapse stress is given as:

$$\sigma_c = \left[\frac{\pi}{4} + 385(0.05 - \eta\beta)^{2.5}\right] \left[\cos\left(\frac{\eta\beta\pi}{2}\right) - \frac{\eta\sin(\beta\pi)}{2}\right] \sigma_y \text{ if } \eta\beta < 0.05 \quad (\text{A.21})$$

$$\sigma_c = \frac{\pi}{4} \left[\cos\left(\frac{\eta\beta\pi}{2}\right) - \frac{\eta\sin(\beta\pi)}{2}\right] \sigma_y \text{ if } \eta\beta \geq 0.05 \quad (\text{A.22})$$

NOTE Unit for π is in radians.

A.5.1.5 Determination of Acceptable Imperfection Size by Option 3

A.5.1.5.1 General

In most offshore pipelines and flowlines, cyclic loading during construction and operation is present. The Option 3 procedures are permitted when significant imperfection growth is expected.

Subject to company approval, validated fitness-for-purpose procedures may be used to develop imperfection acceptance criteria. One of the most widely accepted procedures is BS 7910. The procedures shall be applied by well-qualified analysts/engineers who have the demonstrated command of the principles of fracture mechanics, pipeline welding, and NDT. Any selected procedure shall be taken as a whole in developing the acceptance criteria with appropriate considerations of safety factors. It should be recognized that the basic assumptions of various public-

accessible assessment procedures may be different from those of Options 1 and 2. Mixing parts of different procedures is discouraged.

A.5.1.5.2 Fatigue Flaw Growth

Appropriate fatigue analysis shall be conducted to determine the starting flaw acceptance criteria. Various public-accessible procedures and software are available to determine the flaw growth (e.g. Section 8 of BS 7910). Static fracture resistance shall be checked for all peak loads during the entire fatigue loading spectrum. Available software programs may be used by skilled practitioners to conduct this fatigue analysis and check the static failure conditions during the entire application of the cyclic loads.

The allowable flaw size from Option 1 may be used as the starting flaw sizes for both buried and surface-breaking flaws. If the critical flaw size is reached or failure from static peak loads occurs prior to the end of the service life (with the appropriate design or safety factor), the starting flaw sizes need to be reduced. Care should be taken to select the appropriate flaw growth curves (da/dN curves) for the type of service. Tables 4 and 5 of BS 7910 provide guidance for selection of these curves, and company may provide supplemental information used to generate flaw growth curves for different product conditions inside the pipe. For small D/t ratio pipes through-thickness stress is not uniform. Analyses from multiple initial flaw locations are necessary.

A.5.1.5.3 Inspection Error and Safety Factor on Allowable Imperfect Size

The allowable flaw height shall be reduced by the inspection error extracted from NDT qualification results of qualified inspection system/procedure/operator for the specific project or project with similar material and welding procedure.

A.5.1.6 Transverse Planar Imperfections

Transverse planar imperfections shall be repaired or removed. The height of imperfections that are indicative of stacked weld bead starts and stops shall not exceed the lesser of $1/4$ in. (6.4 mm) or 50 % of the wall thickness.

A.5.2 Acceptable Limits of Volumetric Imperfections

Buried volumetric imperfections, such as slag or porosity, contained in material with high fracture toughness are much less likely to cause failure than planar imperfections. These imperfections may be treated and evaluated as planar imperfections or by the simplified method of Table A.4. Surface-breaking imperfections, and buried imperfections that are recategorized as surface-breaking by the imperfection interaction rules, shall be treated and evaluated as planar imperfections. The minimum CTOD toughness and Charpy impact energy requirements are applicable regardless how the imperfections are evaluated.

Table A.4—Acceptance Limits for Buried Volumetric Imperfections

Imperfection Type	Height or Width	Length
Porosity	Lesser of $1/4$ or 0.25 in.	Less of $1/4$ or 0.25 in.
Slag	Lesser of $1/4$ or 0.25 in.	$4t$

A.5.3 Arc Burns

Arc burns may occur on the internal or external surface of the pipe as a result of inadvertent arc strikes or improper grounding. They generally appear as a pit or cavity visible to the eye or as a dense area on the radiograph. The cavity may be surrounded by a hard HAZ that may be of lower toughness than the base material or the weld deposit.

The acceptance limits for unrepaired arc burns are given in Table A.5 and are based on the premise that the HAZ has zero toughness but that any planar imperfection originating within the HAZ is blunted at the edge of the zone. Substantial data indicate that the total depth of the arc burn, including the HAZ, is less than half the width of the burn.

Table A.5—Acceptable Limits for Unrepaired Arc Burns

Measured Dimension	Acceptance Limit
Width	Lesser of t or $5/16$ in.
Length (any direction)	Lesser of t or $5/16$ in.
Depth (to bottom of crater)	$1/16$ in.

Arc burns that contain cracks visible to the eye or on conventional radiographs are not covered by this annex and shall be repaired or removed.

A.5.4 Imperfection Interaction

If adjacent imperfections are close enough, they may behave as single larger imperfections. Figure A.11 shall be used to determine whether interaction exists. If it does, the effective imperfection sizes shown in Figure A.11 shall be computed and the acceptability of the effective imperfection shall be evaluated by the applicable acceptance criteria. If a repair is indicated, any interacting imperfections shall be repaired in accordance with A.7.

A.6 Record

The type, location, and dimensions of all imperfections accepted in accordance with this annex shall be recorded on suitable forms. This record shall be filed with the radiographs or other records of nondestructive tests of the pipeline.

A.7 Repairs

Any imperfections that are not acceptable under the provisions of this annex shall be repaired or removed in accordance with Section 9 and Section 10

A.8 Nomenclature ¹⁹

a	imperfection height (in. or mm).
c	imperfection half length (in. or mm).
D	pipe outer diameter (in. or mm).
d_n	J integral to CTOD conversion factor (unitless).
E	Young's modulus (ksi or MPa).
J_e	elastic part of J integral (ksi in. or MPa mm).
K_I	stress intensity factor [ksi (in.) ^{1/2} or MPa (mm) ^{1/2}].
K_r	toughness ratio in FAD format (unitless).
L_r	stress ratio in FAD format (unitless).
L_r^{cutoff}	cutoff stress ratio in FAD format (unitless).
n	strain hardening exponent (unitless).
P_r	normalized applied stress or load level, $P_r = \sigma_a / \sigma_f$ (unitless).
t	pipe wall thickness (in. or mm).
α	ratio of pipe diameter to wall thickness, $\alpha = D/t$ (unitless).
β	ration of imperfection length to pipe circumference, $\beta = 2c/\pi D$, (unitless).
δ_e	elastic part of CTOD (in. or mm).

¹⁹ The units shown here are for illustrative purposes. It is necessary to ensure consistent units are used for all computations. Some equations, for example, Equation (A.3), Equation (A.11), Equation (A.12), and Equation (A.13) must use specified units.

δ_{mat}	CTOD toughness (in. or mm).
t	specified pipe wall thickness.
η	ratio of imperfection height to pipe wall thickness, $\eta = alt$, (unitless).
ν	Poisson's ratio (unitless).
σ_a	maximum axial design stress (ksi or MPa).
σ_c	plastic collapse stress (ksi or MPa).
σ_f	flow stress of the pipe material (ksi or MPa).
σ_t, T	ultimate tensile strength of the pipe material (ksi or MPa).
σ_y, Y	specified minimum yield strength of the pipe material, or SMYS, (ksi or MPa).
ϵ_t	uniform strain (unitless)..

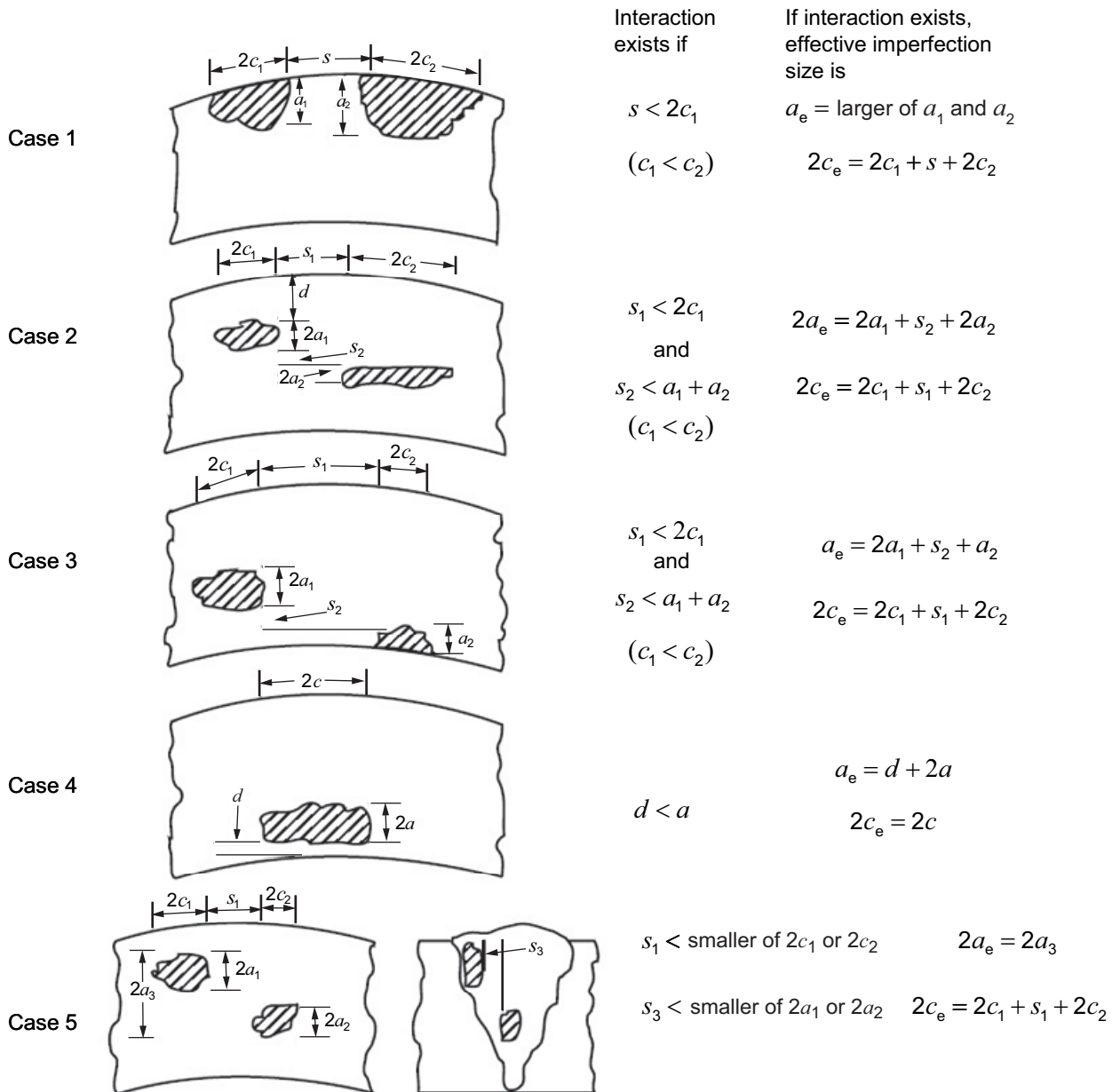

Figure A.11—Criteria for Evaluation of Imperfection Interaction

Annex B (normative)

In-service Welding

B.1 General

This annex covers recommended welding practices for making repairs to or installing appurtenances on pipelines and piping systems that are in service. For the purposes of this annex, in-service pipelines and piping systems are defined as those that contain crude petroleum, petroleum products, or fuel gases that may be pressurized and/or flowing. In-service welds are defined as those that fuse directly into the wall of an in-service pipeline or piping system. This annex does not cover pipelines and piping systems that have been fully isolated and decommissioned or that have not been commissioned.

There are two primary concerns with welding onto in-service pipelines. The first concern is to avoid “burn-through,” where the welding arc causes the pipe wall to be breached. The second concern is for hydrogen cracking, since welds made in service cool at an accelerated rate as the result of the flowing contents’ ability to remove heat from the pipe wall.

Burn-through is unlikely when installing an appurtenance if the wall thickness is 0.250 in. (6.4 mm) or greater, provided that low-hydrogen electrodes (EXX18 type) and normal welding practices are used. Welding onto thinner-wall in-service pipelines is possible and considered routine by many companies; however, special precautions, such as the use of a procedure that limits heat input, are often specified. Burn-through becomes more likely when welding directly onto the pipe, which may occur when depositing the buttering layers of a temper bead deposition sequence or when performing weld deposition repair.

For hydrogen cracking to occur, three conditions must be satisfied simultaneously. These conditions are: hydrogen in the weld, the development of a crack-susceptible weld microstructure, and tensile stress acting on the weld. To prevent hydrogen cracking, at least one of the three conditions necessary for its occurrence must be minimized or eliminated. For welds made onto in-service pipelines, success has been achieved using low-hydrogen electrodes or a low-hydrogen process and, since low hydrogen levels cannot always be guaranteed, using procedures that minimize the formation of crack-susceptible microstructures. The most common procedures use a sufficiently high heat input level to overcome the effect of the flowing contents. Several heat input prediction methods have been developed, including thermal analysis computer models.²⁰ While these or other proven methods are useful in predicting the heat input required for a given in-service welding application, they are not a substitute for procedure qualification (see B.2). Preheating, where practicable, and/or the use of a temper bead deposition sequence, can also reduce the risk of hydrogen cracking. For some pipeline operating conditions, the ability of the flowing contents to remove heat from the pipe wall tends to make the effective use of preheating difficult. Examples of typical temper bead deposition sequences are shown in Figure B.1. To minimize the stress acting on the weld, attention should also be given to proper fit-up to minimize the stress concentration at the root of the weld.

The successful application of in-service welding must achieve a balance between safety on one hand and the prevention of unsatisfactory material properties on the other. For example, if the pipe wall is thin [i.e. less than 0.250 in. (6.4 mm)], it may be necessary to limit heat input to minimize the risk of burn-through; however, a low heat input level may be insufficient to overcome the ability of the contents to remove heat from the pipe wall, resulting in excessive weld cooling rates and a subsequent risk of hydrogen cracking. Thus, a compromise must be reached. When the maximum allowable heat input to avoid burn-through is insufficient to provide adequate protection against hydrogen cracking, then alternative precautions (e.g. a temper bead deposition sequence) must be used.

The majority of this annex pertains to preventing hydrogen cracking in in-service welds. If the pipe wall thickness is less than 0.250 in. (6.4 mm), the risk of burn-through should be considered. The previously mentioned thermal

²⁰ “Development of Simplified Weld Cooling Rate Models for In-service Gas Pipelines,” PRCI Catalog No. L51660 or “Thermal Analysis Model for Hot-tap Welding Version 4.2,” PRCI Catalog No. L51837.

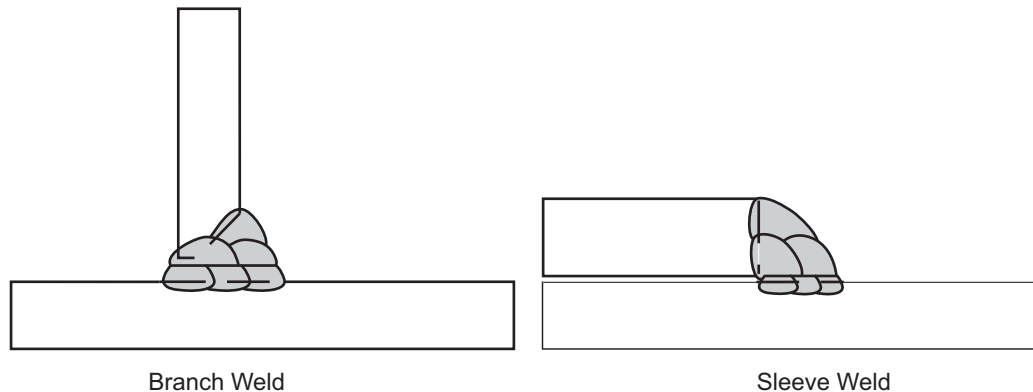

NOTES:

1. A layer of weld metal buttering is first deposited using stringer beads.
2. Higher heat input levels are used for subsequent passes, which refine and temper the HAZ of the first layer.

Figure B.1—Examples of Typical Temper Bead Deposition Sequences

analysis computer models²⁰ or another proven method should be used to determine heat input limits for these applications. Additional consideration should also be given for welding onto in-service pipelines and piping systems that contain products that become explosively unstable upon the application of heat or that contain products that will affect the pipe material by rendering it susceptible to ignition, stress corrosion cracking, or embrittlement. Additional guidance can be found in API 2201.

The requirements for fillet welds in the main body of this document should be applied to in-service welds that contact the carrier pipe, except for the alternative/additional requirements specified in this annex. For in-service welding, where discrepancies exist between this annex and the main body of this document, the annex should govern.

B.2 Qualification of In-service Welding Procedures

B.2.1 General

The procedure qualification requirements for fillet welds in Section 5 should be applied to in-service welds, except for the alternative/additional requirements specified in this annex.

B.2.2 Welding Procedure Specification

B.2.2.1 Specification Information

B.2.2.1.1 Materials

For in-service welds, the carbon equivalent²¹ of the materials to which the procedure applies should be identified in addition to SMYS. Carbon equivalent levels may be grouped.

[paragraph deleted]

B.2.2.1.2 Pipeline Operating Conditions

For in-service welds, the pipeline operating conditions (pipe contents, flow rate, etc.) for which the procedure applies should be identified. Conditions may be grouped.

²¹ CEI_W = %C + %Mn/6 + (%Cu + %Ni)/15 + (%Cr + %Mo + %V)/5.

B.2.2.1.3 Heat Input Range

For procedures intended to overcome the effect of heat removal by the flowing contents by using a sufficiently high heat input level ²² (heat input control procedures), the required heat input range should be specified. For procedures intended to overcome the effect of heat removal by the flowing contents by using temper bead deposition sequence (temper bead procedures), the required heat input range for each layer should be specified.

B.2.2.1.4 Weld Deposition Sequence

For procedures intended to overcome the effect of heat removal by the flowing contents by using temper bead deposition sequence (temper bead procedures), the required weld deposition sequence should be specified. The weld deposition sequence should include tolerances for bead spacing to assure proper tempering of the previous passes.

B.2.3 Essential Variables

B.2.3.1 Changes Requiring Requalification

B.2.3.1.1 Materials

For in-service fillet welds, SMYS is not an essential variable.

NOTE For in-service welds other than fillet welds, the strength of the completed weld meets or exceeds the specified minimum strength of the pipe and fitting material.

An increase in the carbon equivalent above that of the material used for procedure qualification constitutes an essential variable, except as provided below.

A procedure may be used for higher carbon equivalent materials than the material used for procedure qualification provided that the thermal conditions are less severe than the procedure qualification conditions and no increase in the risk of hydrogen cracking results.

B.2.3.1.2 Pipeline Operating Conditions

For in-service welds, an increase in the severity of the pipeline operating conditions (in terms of weld cooling rates) above the group qualified constitutes an essential variable.

B.2.3.1.3 Pipe Wall Thickness

For in-service fillet welds, wall thickness is not an essential variable. However, wall thickness of the materials being welded should be considered when considering the thermal severity of the pipeline operating conditions.

NOTE For weld deposition repairs, the qualified welding procedure is not used on a remaining pipe wall thickness less than what was used during qualification.

B.2.3.1.4 Weld Deposition Sequence

A change from a deposition sequence that relies on tempering to some other deposition sequence constitutes an essential variable. For a deposition sequence that relies on tempering, a change in the bead spacing beyond the limits in the welding procedure specification constitutes an essential variable.

²² Heat Input (kJ/in.) = (Amps × Volts × 60)/[Travel Speed (in./min) × 1000], or Heat Input (kJ/mm) = (Amps × Volts × 60)/[Travel speed (mm/min) × 1000].

B.2.4 Welding of Test Joints

B.2.4.1 General

Pipeline operating conditions that affect the ability of the flowing contents to remove heat from the pipe wall should be simulated while test joints are being made.

NOTE Filling the test section with water and allowing water to flow through the test section while the test joint is being made has been shown to produce thermal conditions equivalent to or more severe than typical in-service welding applications (see Figure B.2). Procedures qualified under these conditions are therefore suitable for any typical in-service application. Other media (e.g. motor oil) may be used to simulate less severe thermal conditions.

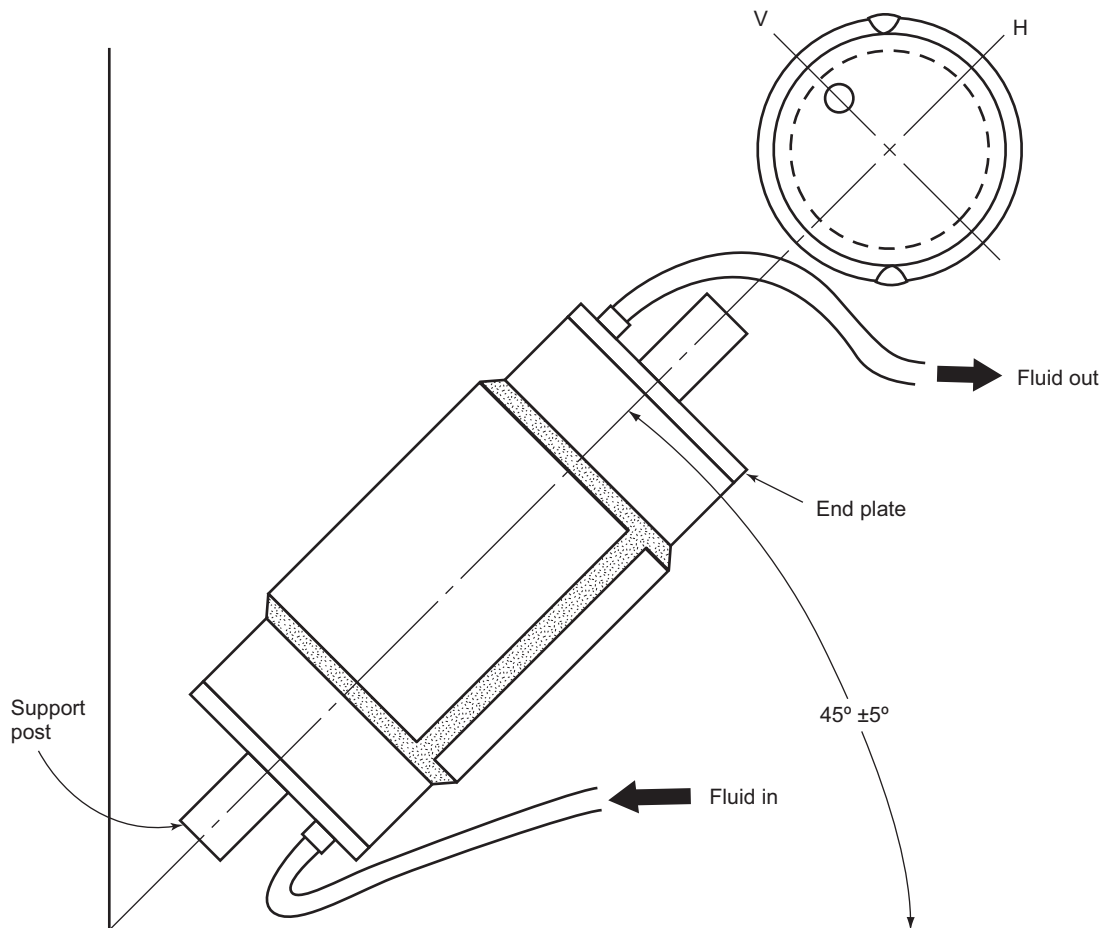

NOTE For a single in-service welder qualification, this test qualifies the welder for all positions. Tests may be performed in other positions which will qualify the welder for that position only.

Figure B.2—Suggested Procedure and Welder Qualification Test Assembly

B.2.4.2 Branch and Sleeve Welds

The requirements in 5.7 for branch and sleeve welds are appropriate for in-service welding.

B.2.4.3 Weld Deposition Repairs

Weld deposition repairs should be deposited on a section of pipe containing simulated wall loss. The area of simulated wall loss should be of sufficient size to remove all the required tests specimens and may consist of a single larger area or multiple smaller areas (see B.2.5.1). Other specimen layouts may be used at the discretion of the company. The remaining wall thickness of the simulated wall loss should be no greater than the minimum value specified in the welding procedure specification. Weld deposition repairs should be deposited in such a way that the original wall thickness is completely restored.

B.2.5 Testing of Welded Joints

B.2.5.1 Preparation

The requirements in 5.8 are appropriate for in-service welding, except that test specimens should be cut from the joint at the locations shown in Figure B.3 or Figure B.4 and the minimum number of specimens and the tests to which they are to be subjected are shown in Table B.1.

B.2.5.2 Longitudinal Seam Welds

The longitudinal seam welds of full encirclement sleeves should be tested in accordance with 5.6. The backing material, if used, should be removed and the specimens may be flattened at room temperature before testing.

B.2.5.3 Branch and Sleeve Welds and Weld Deposition Repairs

Branch and sleeve welds and weld deposition repairs should be tested in accordance with 5.8, except for testing of the additional specimens indicated in B.2.5.1.

B.2.5.4 Macrosection Tests—Branch and Sleeve Welds

B.2.5.4.1 Preparation

The macrosection test specimens (see Figure B.5) should be at least $\frac{1}{2}$ in. (13 mm) wide. They may be machine cut, or they may be oxygen cut oversized and machined by a nonthermal process to remove at least $\frac{1}{4}$ in. (6 mm) from the side(s) that will be prepared. For each macrosection test specimen, at least one face should be ground to at least a 600 grit finish and etched with a suitable etchant, such as Nital, ammonium persulfate, or dilute hydrochloric acid, to give a clear definition of the weld structure.

B.2.5.4.2 Visual Examination

The cross section of the weld is to be visually examined with lighting that will sufficiently reveal the details of the weld soundness. The use of optical devices or dye penetrants is not necessary.

B.2.5.4.3 Hardness Testing

Two of the four macro test specimens for branch and sleeve welds and both macro test specimens for weld deposition repairs should be prepared for hardness testing in accordance with ASTM E384. A minimum of five indentations should be made using a Vickers indenter and a 10-kg load to determine the maximum hardness value in the coarse-grained HAZ at the weld toe of each specimen.

B.2.5.4.4 Requirements

A visual examination of the cross section of the weld should show that it is completely fused at the root and free of cracks. The fillet weld should have leg lengths that are at least equal to the lengths specified in the procedure qualification and should not deviate in concavity or convexity by more than $\frac{1}{16}$ in. (1.6 mm). The depth of the undercutting should not exceed $\frac{1}{32}$ in. (0.8 mm) or 12 $\frac{1}{2}$ % of the pipe wall thickness, whichever is smaller.

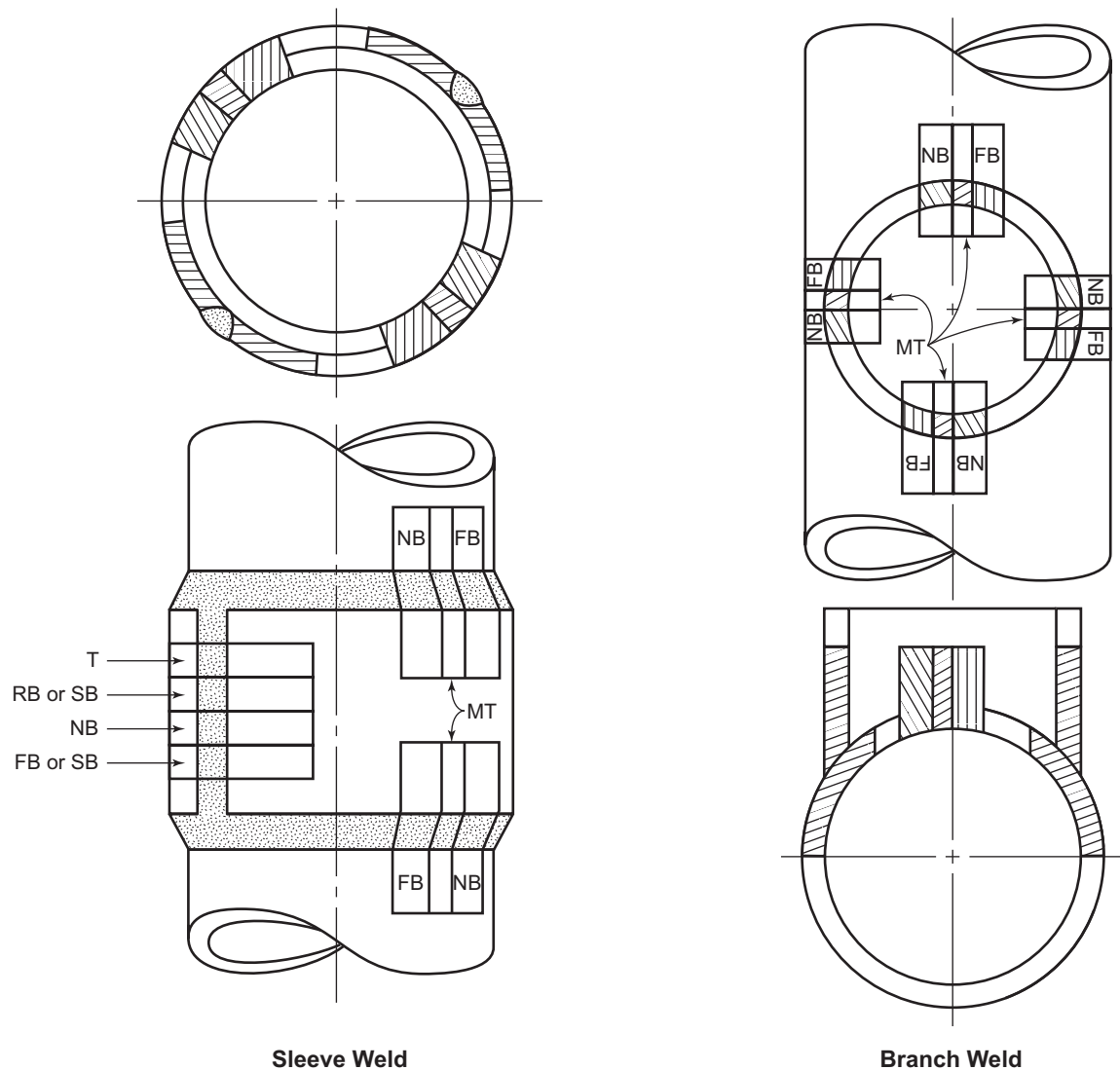

NOTE T = tensile; RB = root bend; FB = face bend; NB = nick break; SB = side bend; MT = macro test.

Figure B.3—Suggested Location of Test Specimens for Sleeve and Branch Welds

Procedures that produce HAZ hardness values in excess of 350 HV should be evaluated with regard to the risk of hydrogen cracking.

B.2.5.5 Face Bend Test—Branch and Sleeve Welds and Weld Deposition Repairs

B.2.5.5.1 Preparation

The face bend specimens (see Figure B.6) should be approximately 9 in. (230 mm) long and approximately 1 in. (25 mm) wide. They may be machine cut, or they may be oxygen cut oversized and machined by a nonthermal process, to remove at least $\frac{1}{8}$ in. (3 mm) from each side. The sides should be smooth and parallel, and the long edges should be rounded. The sleeve or branch and reinforcements should be removed flush with the surface but not below the surface of the test specimen. Any undercut should not be removed. Specimens should not be flattened prior to testing.

NOTE In lieu of taking separate specimens for the face bend test, the remaining portion of the nick break specimens may be used.

Option 1:

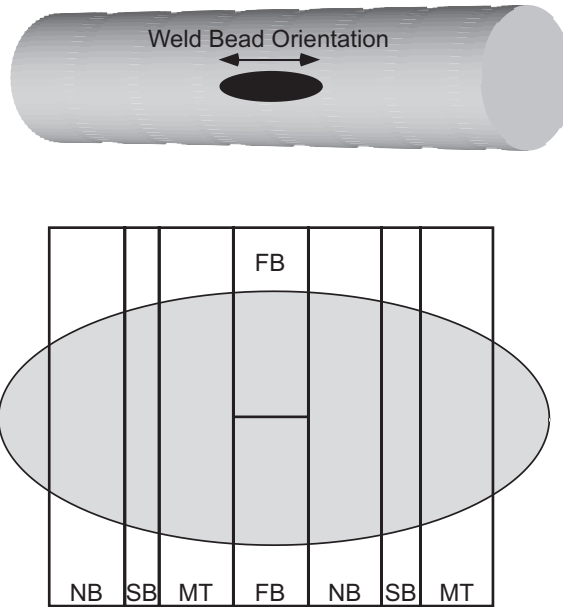

Option 2:

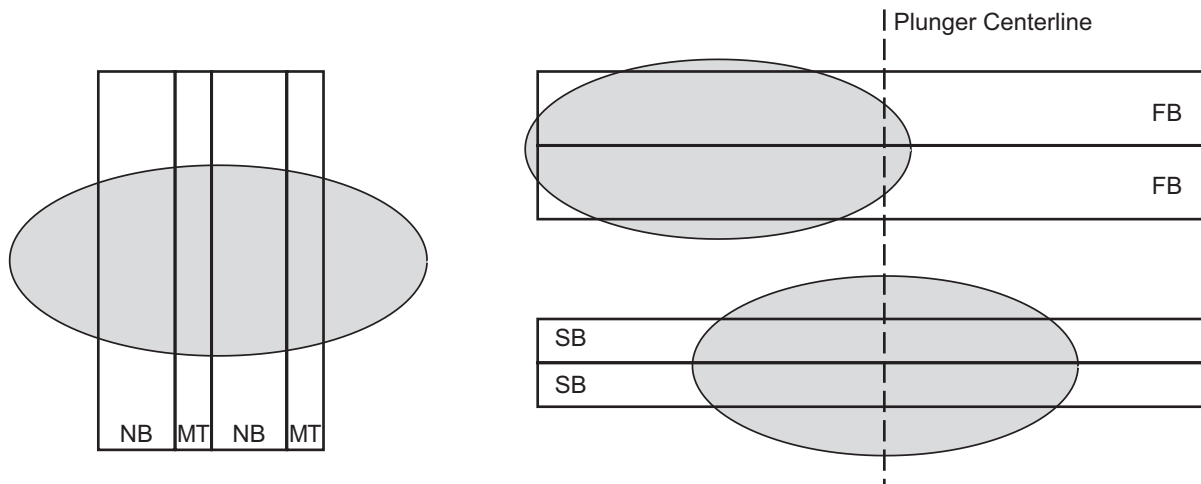

NOTE 1 NB = nick-break; SB = side bend; MT = macro test; FB = face bend.

NOTE 2 The area of simulated wall loss should be of sufficient size to remove all the required test specimens and may consist of a single larger area (Option 1) or multiple smaller areas (Option 2).

Figure B.4—Suggested Location of Test Specimens for Weld Deposition Repair

Table B.1—Type and Number of Specimens—In-service Welding Procedure Qualification Test

Wall Thickness	Weld Type	Number of Specimens ^a						
		Tensile	Nick Break	Root Bend	Face Bend	Side Bend	Macro Test	Total
≤0.500 in. (12.7 mm)	Groove	2	2	2	2			8
	Sleeve		4 ^b		4		4	12
	Branch		4 ^b		4		4	12
	WDR ^c		2		4		2 ^d	8
>0.500 in. (12.7 mm)	Groove	2	2			4		8
	Sleeve		4 ^b		4		4	12
	Branch		4 ^b		4		4	12
	WDR ^c		2		2	2	2 ^d	8

^a For pipe or branch OD less than or equal to 4.500 in. (114.3 mm), two welds may be required.

^b At the owner's option, the remaining portion of these specimens may be prepared for and submitted to the face bend test (see B.2.5.5) after they are submitted to the nick break test.

^c Weld deposition repairs.

^d At the company's option, the remaining portion of these specimens may be prepared for and submitted to the face bend or side bend test (see B.2.5.5 or 5.6.5) after they are submitted to the macro test.

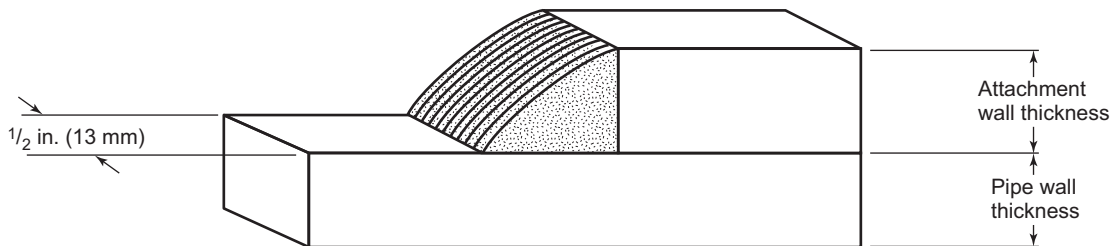

NOTE Smooth and etch at least one face of each weld specimen cross section with a suitable etchant to give a clear definition to the weld structure.

Figure B.5—Macro Test Specimen—In-service Welds

B.2.5.5.2 Method

The face bend specimens should not be tested less than 24 hours after welding. The face bend specimens should be bent in a guided-bend test jig similar to that shown in Figure 8. Each specimen should be placed on the die with the weld toe area at midspan. The face of the weld should be placed toward the gap. The plunger should be forced into the gap until the curvature of the specimen is approximately U shaped.

B.2.5.5.3 Requirement

The face bend test should be considered acceptable if, after bending, no crack or other imperfection exceeding $1/8$ in. (3 mm) or one-half the specified wall thickness, whichever is smaller, in any direction is present in the weld metal or HAZ. Cracks that originate on the outer radius of the bend along the edges of the specimen during testing and that are less than $1/4$ in. (6 mm), measured in any direction, should not be considered unless obvious imperfections are observed.

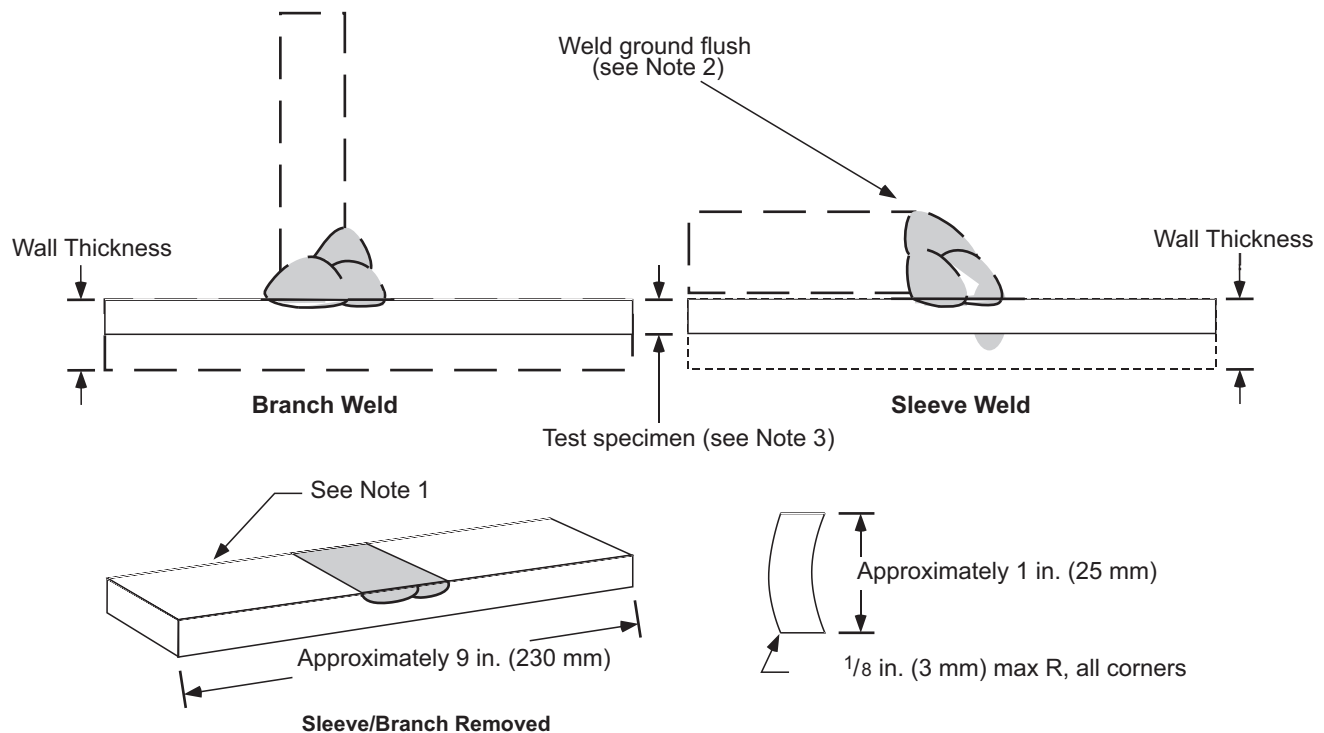

NOTES:

1. Test specimens may be machine cut or oxygen cut oversized and machined (see B.2.5.5.1).
2. The sleeve or branch weld reinforcement is removed flush with the surface of the test specimen. The branch weld test specimen is shown in the axial direction; specimens in the other direction are curved. Test specimens are not flattened prior to testing.
3. Where wall thickness is greater than 0.500 in. (12.7 mm), it may be reduced to 0.500 in. (12.7 mm) by machining the inside surface.
4. In lieu of taking separate specimens for the face bend test, the remaining portion of the nick-break specimens may be used.

Figure B.6—Face Bend Test Specimen

B.3 In-service Welder Qualification

B.3.1 General

For in-service welding, the welder should be qualified to apply the specific procedure being used according to the requirements of 6.2, except for the alternative/additional requirements specified in this annex.

A welder qualified on pipe having an OD of less than 12.750 in. (323.9 mm) should be qualified for all diameters less than or equal to the diameter used in the qualification test. A welder qualified on pipe having an OD of greater than or equal to 12.750 in. (323.9 mm) should be qualified for all pipe diameters. A welder who has an existing multiple qualification to 6.3 and an in-service qualification to B.3 should be qualified as an in-service branch or sleeve welder for all positions, all diameters, and all wall thicknesses within the limits of the essential variables in 6.3.

For weld deposition repairs, welders who perform test welds on the bottom of the pipe are qualified for welding in all positions. Welders who perform test welds on the side of the pipe are qualified for welding only on the side and top of the pipe. Welders who perform test welds on the top of the pipe are qualified for welding only on the top of the pipe.

B.3.2 Welding of Test Joint

For in-service welding, pipeline operating conditions that affect the ability of the flowing contents to remove heat from the pipe wall should be simulated while test joints are being made.

NOTE Filling the test section with water and allowing water to flow through the test section while the test joint is being made has been shown to produce thermal conditions equivalent to or more severe than typical in-service welding applications (see

Figure B.2). Welders qualified under these conditions are therefore qualified for any typical in-service application. Other media (e.g. motor oil) may be used to simulate less severe thermal conditions.

In addition to making the test joint used for the destructive testing described in B.3.3, the welder should demonstrate to the satisfaction of the company the ability to comply with aspects of the welding procedure specification that are intended to avoid the development of crack-susceptible microstructures and/or prevention of burn-through. For example, for heat input control procedures, the company may choose to require the welder to demonstrate the ability to maintain a heat input level within the range specified in the welding procedure specification. For temper bead and weld deposition repair procedures, the company may choose to require the welder to demonstrate bead placement within the dimensional tolerances specified in the welding procedure specification and the ability to maintain a heat input level within the range specified in the welding procedure specification.

B.3.3 Testing of Welded Joints

The weld should be tested and considered to be acceptable if it meets the requirements of 6.4 and 6.5. For longitudinal seam welds, the minimum number of specimens and the tests to which they should be subjected is shown in Table B.2. For weld deposition welders, the minimum number of specimens and tests to which they should be subjected is shown in Table B.1.

Table B.2—Type and Number of Test Specimens for Longitudinal Seam Welds—Welder Qualification Test

Wall Thickness	Tensile	Number of Specimens				
		Nick Break	Root Bend	Face Bend	Side Bend	Total
≤0.500 in. (12.7 mm)	1	1	1	1		4
>0.500 in. (12.7 mm)	1	1			2	4

B.3.4 Records

The pipeline operating conditions (pipe contents, flow rate, etc.) for which the welder is qualified should be identified. Conditions may be grouped.

B.4 Suggested In-service Welding Practices

B.4.1 General

The requirements for production welding in Section 7 should be applied to in-service welds, except for the alternative/additional requirements specified in this annex.

Before welding onto an in-service pipeline or piping system, welders should consider aspects that affect safety, such as operating pressure, flow conditions, and wall thickness at the location of the welding. The areas to be welded should be inspected to ensure that imperfections are not present and that the wall thickness is adequate. All welders performing repair work should be familiar with the safety precautions associated with cutting and welding on piping that contains or has contained crude petroleum, petroleum products, or fuel gases. Additional guidance can be found in API 2201.

B.4.2 Alignment

B.4.2.1 Fit-up

For sleeve and saddle welds, the gap between the sleeve or saddle and the carrier pipe should not be excessive. Clamping devices should be used to obtain proper fit-up. When necessary, weld metal build-up on the carrier pipe can be used to minimize the gap.

B.4.2.2 Root Opening—Longitudinal Seam Welds

For longitudinal butt welds of full encirclement sleeves, when 100 % penetration is required, the root opening (the space between abutting edges) should be sufficient. These joints should be fitted with a mild steel back-up strip or suitable tape to prevent penetration of the weld into the carrier pipe.

NOTE Penetration of the longitudinal butt weld into the carrier pipe is undesirable since any crack that might develop is exposed to the hoop stress in the carrier pipe.

B.4.3 Welding Sequence

Suggested sleeve and branch welding sequences are shown in Figure B.7 through Figure B.12. For full-encirclement fittings requiring circumferential fillet welds, the longitudinal seams should be completed before beginning the circumferential welds. The circumferential weld at one end of the fitting should be completed before beginning the circumferential weld at the other end. For other types of fittings, a welding sequence that minimizes residual stress should be used.

Guidelines for weld deposition repair have been developed which include preparation prior to welding and weld deposition sequence.²³ For example, a perimeter pass should be used to establish a boundary beyond which no subsequent welding is allowed. The first layer of fill passes should be deposited using established heat input limits to minimize the risk of burn-through. A second perimeter pass should be used to temper the HAZ at the toe of the first perimeter pass. Higher heat input fill passes should be used for subsequent layers to further temper the initial passes, again observing established heat input limits if necessary. Additional layers should be deposited, as necessary, for proper filling.

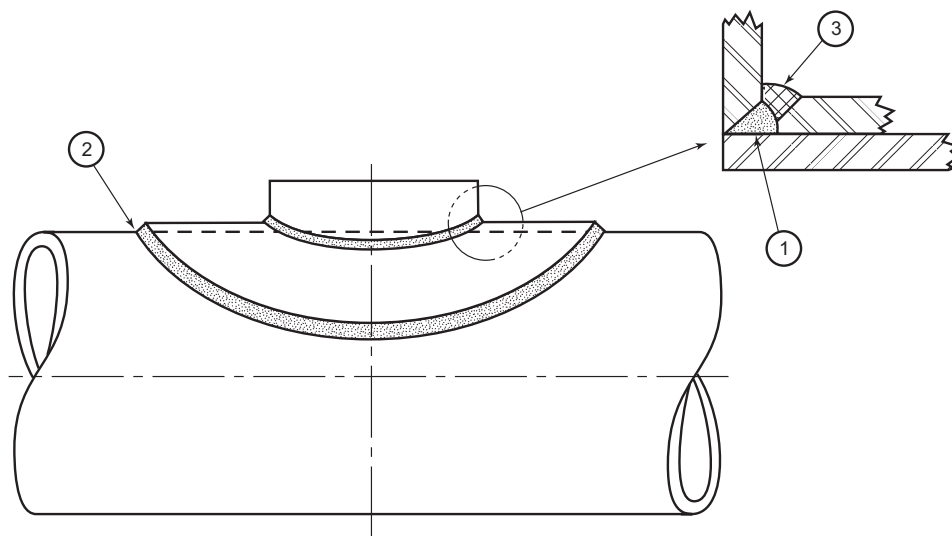

NOTE This is the suggested welding sequence; others may be followed at the discretion of the company.

Figure B.7—Reinforcing Pad

²³ W. A. Bruce and W. E. Amend, "Guidelines for Pipeline Repair by Direct Deposition of Weld Metal," WTIA/APIA Welded Pipeline Symposium, Welding Technology Institute of Australia, Sydney, Australia, April 3, 2009.

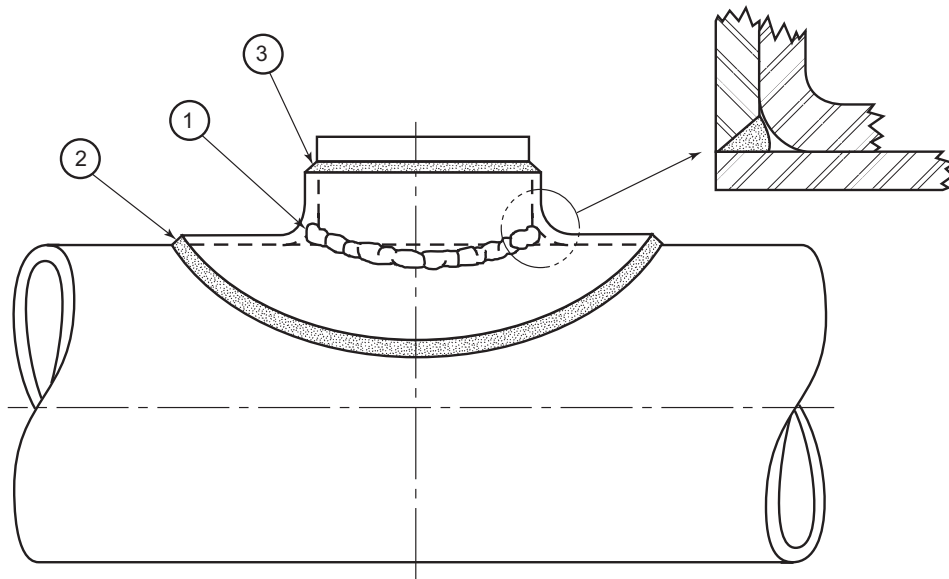

NOTE This is the suggested welding sequence; others may be followed at the discretion of the company.

Figure B.8—Reinforcing Saddle

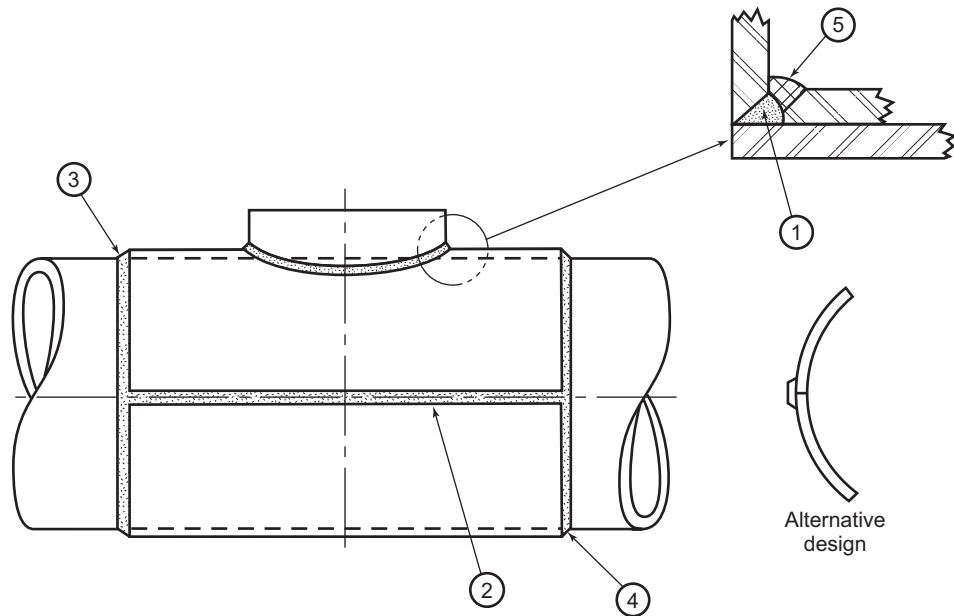

NOTE This is the suggested welding sequence; at the discretion of the company, others may be followed and circumferential welds, numbers 3 and 4, need not be made.

Figure B.9—Encirclement Sleeve

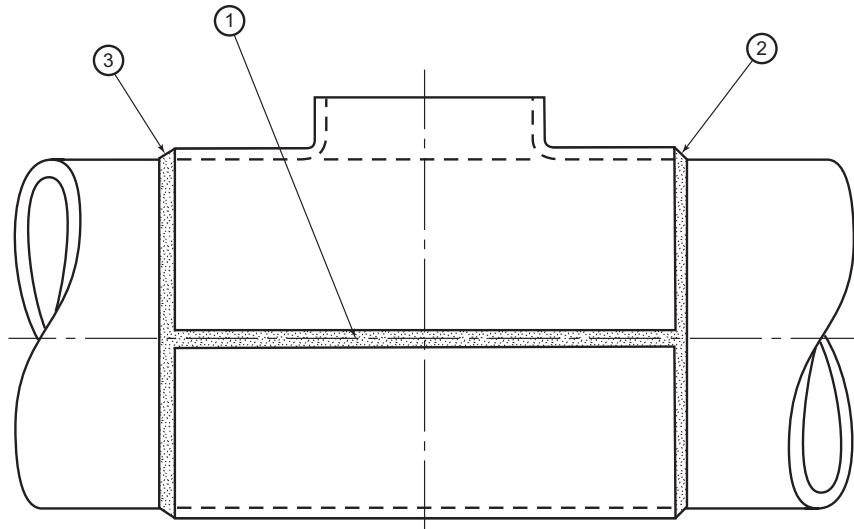

NOTE 1 This is the suggested welding sequence; others may be followed at the discretion of the company.

NOTE 2 When in operation, the fitting is at pipeline pressure.

Figure B.10—Encirclement Tee

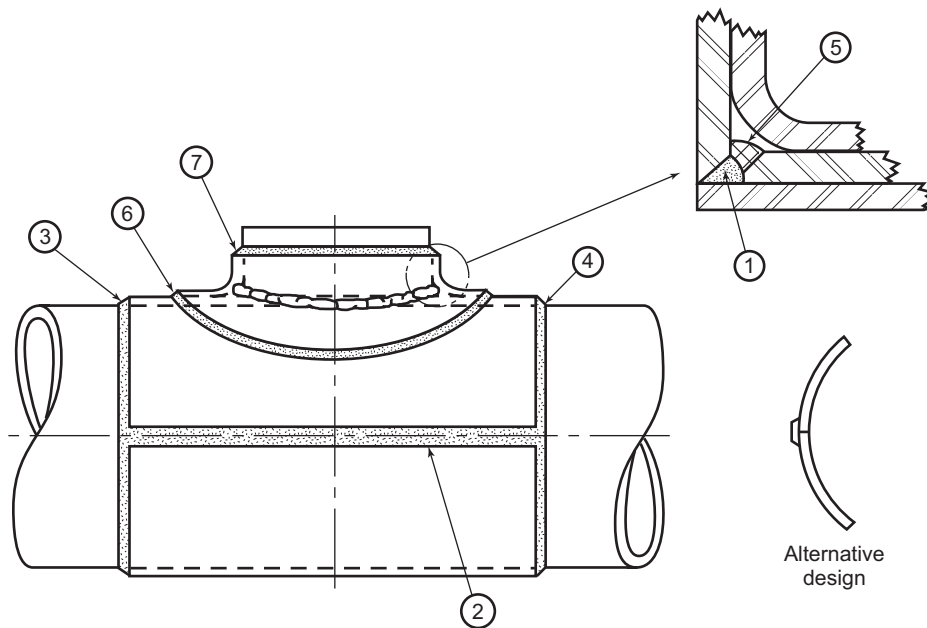

NOTE This is the suggested welding sequence; at the discretion of the company, others may be followed and circumferential welds, numbers 3 and 4, need not be made.

Figure B.11—Encirclement Sleeve and Saddle

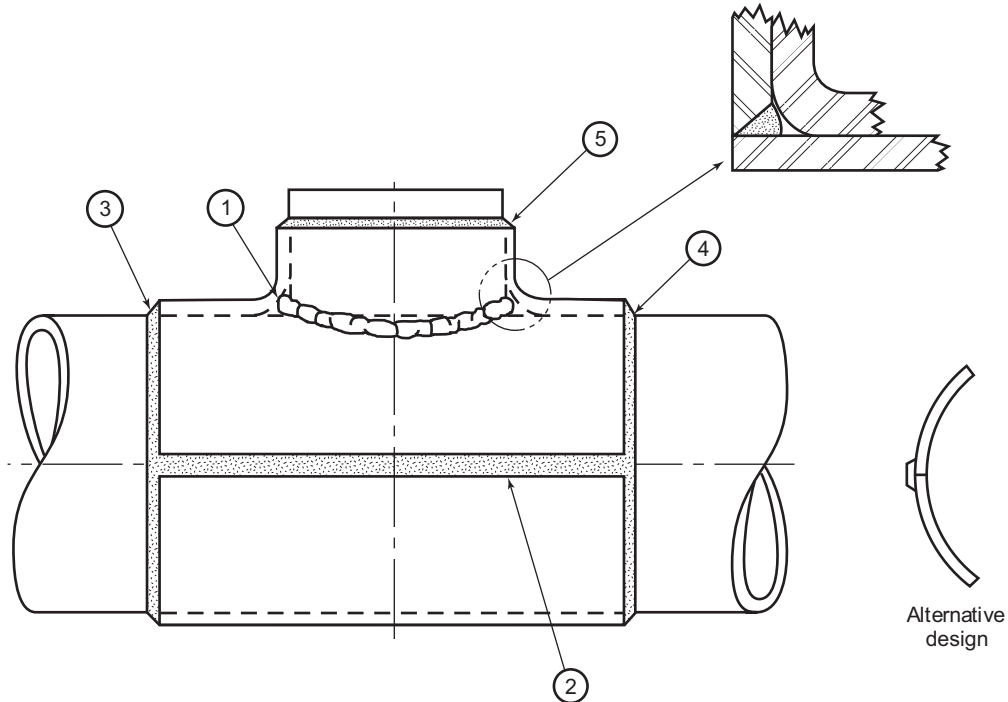

NOTE This is the suggested welding sequence; at the discretion of the company, others may be followed and circumferential welds, numbers 3 and 4, need not be made.

Figure B.12—Encirclement Saddle

B.4.4 Weld Direction

In-service welds should be deposited in the circumferential direction (parallel to the hoop stress direction) whenever possible.

B.5 Inspection and Testing of In-service Welds

The requirements for inspection and testing in Section 8 should be applied to in-service welds, except for the alternative/additional requirements specified in this annex.

Since in-service welds that contact the carrier pipe may be particularly susceptible to underbead or delayed hydrogen cracking, an inspection method that is capable of detecting these cracks, particularly at the carrier pipe weld toe, should be used.

NOTE Magnetic particle testing, ultrasonic testing, or a combination of both, using properly developed, qualified, and approved procedures, have been shown to be effective at detecting hydrogen cracks at the toe of sleeve-, saddle-, and branch-to-carrier pipe welds. Ultrasonic testing, radiographic testing, or a combination of both are effective for volumetric inspection for weld deposition repairs.

When determining appropriate delay times prior to inspection for hydrogen cracking, the time-dependant nature of cracking should be considered, as well as the probability of the weld to cracking. Longer delay times decrease the chance that cracking can occur after inspection has been completed. The probability of cracking, and thus the importance of determining an appropriate delay time, can be minimized by using more conservative welding procedures.

B.6 Standards of Acceptability: NDT (Including Visual)

The standards of acceptability in Section 9 for imperfections located by NDT should be applied to in-service welds. For weld deposition repair, the weld length is defined as the maximum weld length in the direction in which the defect is oriented.

B.7 Repair and Removal of Defects

The requirements in Section 10 for the repair and removal of defects should be applied to in-service welds. Care should be taken during the removal of the defect to ensure that the wall thickness is not reduced to less than that which is acceptable for the operating pressure of the carrier pipe.

Annex C (normative)

Requests for Interpretation and Request for Revision to the Document

C.1 Introduction

The API-AGA Joint Committee on Oil and Gas Pipeline Field Welding Practices will consider written requests for interpretations and revisions in a formal manner. The Committee's activities in this regard are limited strictly to interpretations of this standard, or to the consideration of revisions to this standard on the basis of new data or technology. Such requests are handled as expeditiously as possible, but due to the complexity of the work and the procedures that shall be followed, some responses may require considerable time. As a matter of policy, API does not approve, certify, rate, or endorse any item, construction, proprietary device, or activity related to the use of this standard. Accordingly, any requests for interpretation requiring such consideration shall not be addressed. API does not act as a consultant on specific welding problems or on the general application or understanding of this standard. If, based on the information submitted in the request for interpretation, it is the opinion of the Committee that the inquirer should seek professional assistance, the request for interpretation is not addressed with the recommendation that such assistance be obtained. Requests for interpretation that do not provide the information needed for the Committee's full understanding shall not be addressed, and the inquirer is so notified.

C.2 Requirements

C.2.1 General

Requests for interpretation shall be limited strictly to interpretations of this standard (and not include interpretations of any normative references), or to the consideration of revisions to this standard on the basis of new data or technology. Requests shall be submitted in writing. Requests shall contain the name, address, and affiliation of the inquirer and shall provide enough information for the committee to fully understand the point of concern in the inquiry.

Requests for interpretation or proposed revisions to the documents should be directed to:

Standards Department
API
1220 L Street, NW
Washington, DC 20005
standards@api.org

C.2.2 Scope

Each request or interpretation shall be limited to only one single provision of the standard, however the point of the inquiry may include two or more interrelated provisions as references or supporting information. The particular provision(s) shall be identified, including reference to the applicable edition, addenda, and errata.

C.2.3 Purpose of Inquiry

The purpose of the inquiry shall be stated. The purpose may be either to obtain an interpretation or to propose consideration of a revision to a particular provision in the standard.

C.2.4 Content

The inquiry should be concise, yet complete, to enable the Committee to quickly and fully understand the point of the inquiry. Omit superfluous background information. The inquiry should be technically and editorially correct. If the point of the inquiry is to obtain an interpretation, the inquiry shall be stated in such a manner that the response to the inquiry is either “yes” or “no”. The Committee shall not address inquiries that pose questions of “how” or “why”. If the point of the inquiry is to obtain a revision of the standard, the inquiry shall provide technical justification for that revision.

C.2.5 Proposed Reply

A request for interpretation may include a proposed reply, stating a believed interpretation of the requirements of the provision in question, or recommended wording for a revision.

C.2.6 Additional/New Proposed Processes

Processes other than those described in this document can be considered for inclusion in this standard. Persons who wish to have other processes included shall submit, as a minimum, the following information for the committee’s consideration:

- a) a description of the welding process,
- b) a proposal on the essential variables,
- c) a welding procedure specification,
- d) weld inspection methods,
- e) types of weld imperfections and their proposed acceptance limits,
- f) repair procedures.

C.2.7 Response Time by the Committee

The Committee shall review and provide a response to a request for interpretation as quickly as possible. The Committee shall review the requests in the order they were received by the API. However, since some responses may require input from several sources, a response may take up to one year to formulate and issue to the inquirer. The Committee shall not accelerate this process in order to meet a deadline or schedule requirement of the inquirer. The inquirer should take into consideration this time frame.

For proposals of revision that are submitted, the Committee shall determine the need for immediate change to/ inclusion in the document (an Addendum) or if the revision may be delayed until the next overall edition of the document is published.



AMERICAN PETROLEUM INSTITUTE

1220 L Street, NW
Washington, DC 20005-4070
USA

202-682-8000

Additional copies are available online at www.api.org/pubs

Phone Orders: 1-800-854-7179 (Toll-free in the U.S. and Canada)
303-397-7956 (Local and International)
Fax Orders: 303-397-2740

Information about API publications, programs and services is available
on the web at www.api.org.

Product No. D110421

اگر تمایل دارید هر روز
محتوای جذاب متنی، ویدئویی و اینفوگرافیک
از موضوعات متنوع مواد مهندسی و فرایندهای ساخت و تولید
را مشاهده و دانلود کنید
و از اخبار، رویدادها و تحلیل های صنعتی مطلع باشید،
بازدید از عصر مواد و شبکه های اجتماعی آن را
در برنامه وب گردی های روزانه خود قرار دهید.



www.asremavad.com